

DuPont Performance Building Solutions

DuPont Self-Adhered Flashing Products Installation Guidelines

Installation of Integral Flanged Windows in
Recessed Openings **BEFORE** Water-Resistive Barrier
(WRB) Is Installed.

For Up To 4" Recess Using Single and Double Stud
Window Framing

For Buildings Less Than 5 Stories and Low-Rise
Multi-Family Residential Buildings Less Than 6 Stories

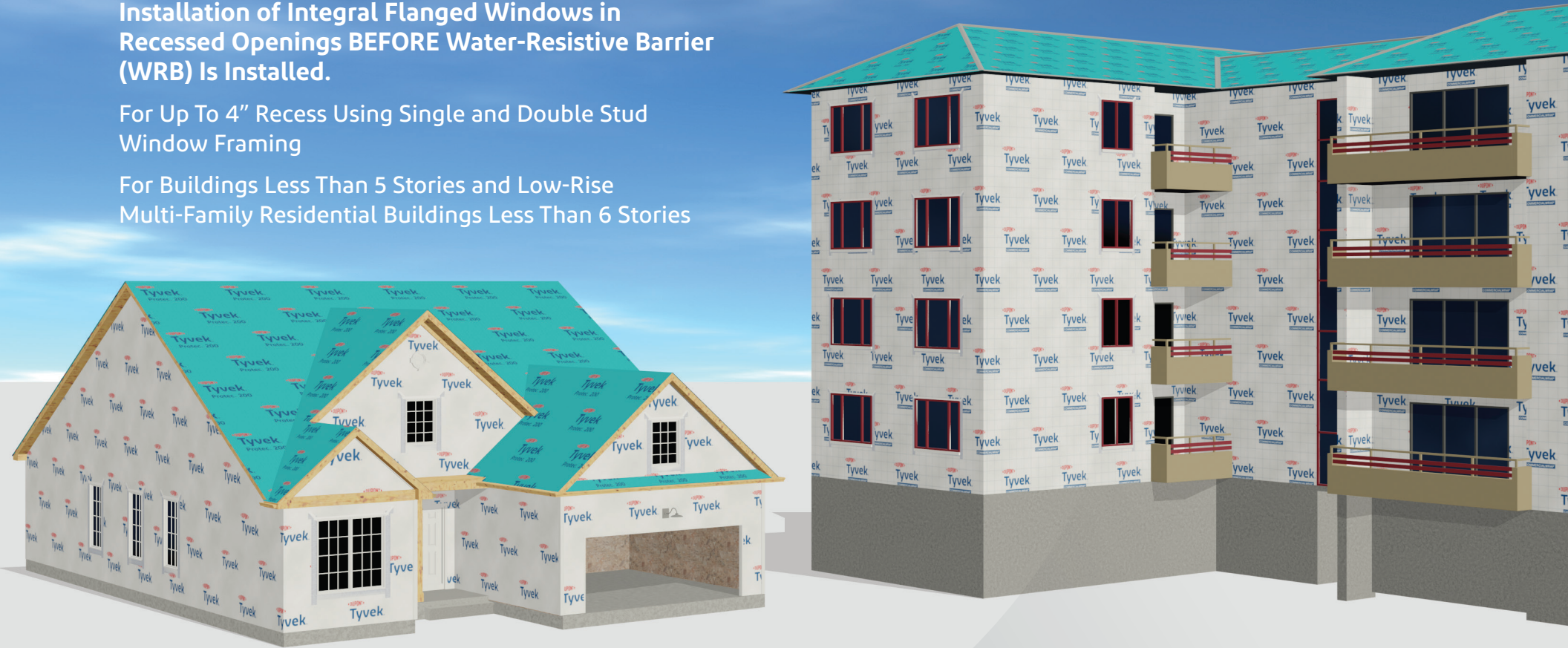

March 2020

Table of Contents

Applicable Products	4
Required Materials Based on Project Requirements, Details, and Specifications*	4
Warranty.....	4
General Instructions.....	4
Key Installation Requirements for Drainable Window/Door Installation Under the Limited Product and Labor Warranty.....	5
Field Preparation of Recessed Window Corner Using DuPont™ FlexWrap™	6
Fabricate four Recessed Window Corners	7
DuPont Self-Adhered Flashing Products – Installation Guidelines for Up to 4” Recess Using Single and Double Stud Window Framing.....	9
Corner Release Paper Removal Guide for Alternative Method described on page 6.....	17

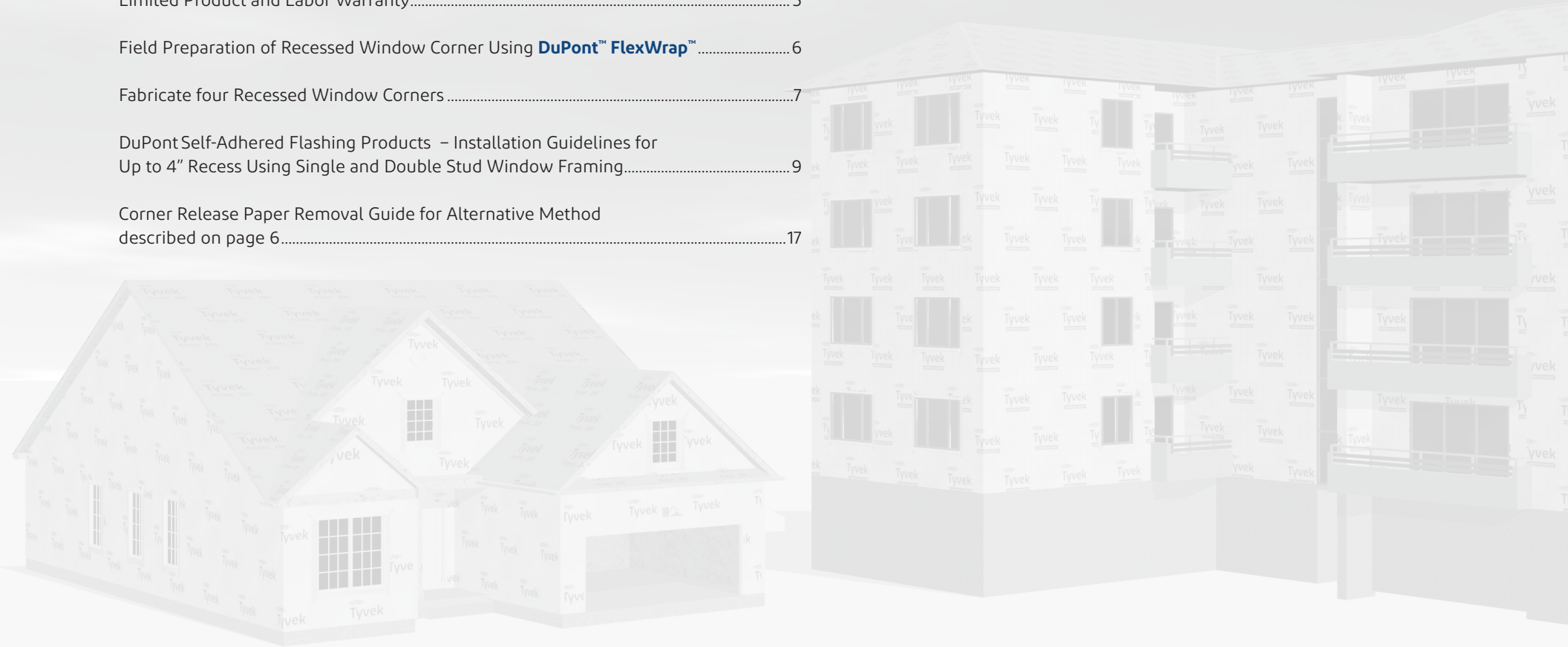

Applicable Products

Water-Resistive Barriers (WRB)

Product	Dimensions	Area
DuPont™ Tyvek® HomeWrap®	3 ft x 100 ft	300 sq ft
	3 ft x 165 ft	495 sq ft
	5 ft x 200 ft	1,000 sq ft
	9 ft x 100 ft	900 sq ft
	9 ft x 150 ft	1,350 sq ft
	10 ft x 100 ft 10 ft x 150 ft	1,000 sq ft 1,500 sq ft
DuPont™ Tyvek® StuccoWrap®	5 ft x 200 ft	1,000 sq ft
DuPont™ Tyvek® DrainWrap™	9 ft x 125 ft	1,125 sq ft
	10 ft x 125 ft	1,250 sq ft
DuPont™ Tyvek® ThermaWrap™ LE	5 ft x 150 ft	750 sq ft
	9 ft x 100 ft	900 sq ft
DuPont™ Tyvek® CommercialWrap®	5 ft x 200 ft	1,000 sq ft
	10 ft x 125 ft	1,250 sq ft
DuPont™ Tyvek® CommercialWrap® D	5 ft x 200 ft	1,000 sq ft
	10 ft x 125 ft	1,250 sq ft

Flashing Products

Product	Width
DuPont™ FlexWrap™ (Formerly DuPont™ FlexWrap™ NF)	6 in
	9 in
DuPont™ StraightFlash™	4 in
	9 in
DuPont™ VersaFlange™ (Formerly DuPont™ StraightFlash™ VF)	6 in
DuPont™ Flashing Tape	4 in
	6 in
	9 in
	12 in

Required Materials Based on Project Requirements, Details, and Specifications*

- DuPont™ Tyvek® Tape
- DuPont™ Tyvek® Wrap Cap Fasteners or recommended fastening system
- Great Stuff Pro™ Window & Door Polyurethane Foam Sealant
- DuPont™ Residential Sealant, or other recommended sealant
- DuPont™ Adhesive/Primer
- Backer Rod
- Brushes for Surface Preparation
- J-Roller

*Apply per manufacturers' guidelines. For non DuPont products, DuPont assumes no liability in use of recommended products; installers need to evaluate suitability of recommended products in their end-use applications.

Warranty

Please refer to the [DuPont Weatherization Products 10-Year Limited Warranty for Buildings Less Than 5 Stories and Low-Rise Multi-Family Residential Buildings Less Than 6 Stories](#).

NOTE: In order to make a claim under the DuPont Performance Building Solutions 10-Year Limited Product and Labor Warranty, you must have met all of the terms and conditions of the warranty, including use of the applicable DuPont Installation Guidelines. In the event that a specific detail or installation technique is not covered in the DuPont Installation Guidelines at the time you are building, then the Key Installation Requirements outlined in this document must have been followed in order to make a claim under the warranty. It is in the sole discretion of DuPont to determine if full compliance with the Key Installation Requirements exists. Please contact DuPont or a DuPont™ Tyvek® Specialist if you have any questions regarding any DuPont Installation Guideline.

General Instructions

These installation guidelines are intended **for buildings less than 5 stories and low-rise multi-family residential buildings less than 6 stories** when performance requirements do not exceed ASTM E1677 (65 mph equivalent structural load and 15 mph equivalent wind-driven rain water infiltration), and window/door design ratings that do not exceed DP45.

DuPont Self-Adhered Flashing Products should be installed on clean, dry surfaces that are free of frost. Wipe surfaces to remove moisture, dirt, grease and other debris that could interfere with adhesion.

Adverse weather conditions or cold temperatures may require use of a primer to promote adhesion of **DuPont Self-Adhered Flashing Products** to most common building materials. Concrete, masonry, and fiber-faced exterior gypsum board require the use of **DuPont™ Adhesive/Primer**.

Apply pressure along entire surface of flashing for a good bond using firm hand pressure, J-roller, or alternate tool without sharp edges (such as a plastic carpet tuck tool) to assist with application of uniform pressure during installation of **DuPont Self-Adhered Flashing Products**. Remove all wrinkles and bubbles that may allow for water intrusion by smoothing surface and repositioning as necessary.

If rigid back dam is desired, cut the corner back dam the length of the sill and nail into place on the interior edge of the sill prior to installation of **DuPont™ FlexWrap™**. Then install **FlexWrap™** over sill and corner guard back dam. If using 6" **FlexWrap™** with optional rigid back dam, seal ends of corner guard with **DuPont™ Residential Sealant** or recommended sealant.

Door and window rough sill framing must be level or slightly sloped to the exterior to ensure proper drainage to the exterior. This best practice ensures continuous support with positive slope to the exterior.

DuPont Self-Adhered Flashing Products are not intended for through-wall flashing applications.

DO NOT STRETCH FlexWrap™ when installing along the length of sills or jambs. **FlexWrap™** is only intended to be extended when fanned out at corners or curved sections.

DuPont Self-Adhered Flashing Products perform best when installed at temperatures above 25°F (-4°C).

Avoid placing **DuPont™ Tyvek® Wrap Cap Fasteners** where flashing or **DuPont™ Tyvek® Tape** will be installed; however, **Tyvek® Wrap Cap Fasteners** can be applied over the flashing.

Please call 1-800-448-9835, visit building.dupont.com, or consult your local **DuPont™ Tyvek®** Specialist for additional information and installation support.

Key Installation Requirements for Drainable Window/Door Installation Under the Limited Product and Labor Warranty

When flashing windows or doors, the following principles must be followed:

- When installed properly, **DuPont™ StraightFlash™**, **FlexWrap™**, and **DuPont™ Flashing Tape** provide nail sealability at window/door openings to help protect critical window-wall interfaces. Metal sill pan flashing may be used, but must not replace flexible sill flashing that provides nail sealability.
- DuPont Self-Adhered Flashing Products comply with AAMA 711-13, *Voluntary Specification for Self Adhering Flashing Used for Installation of Exterior Wall Fenestration Products*, which has a modified version of ASTM D 1970 that is more representative for vertical wall applications.
- Direct water onto an acceptable air and water barrier drainage plane with an unobstructed path to the exterior of the wall. Provide a drainage path for any water intrusion through the window/door attachment system that collects at the sill.
- Properly integrate flashing with acceptable **DuPont™ Tyvek® WRB** in accordance with the details in this installation guideline. DuPont Self-Adhered Flashing Products must be applied with a minimum 2" lap onto the WRB.
- DuPont requires that **FlexWrap™** and **StraightFlash™** be covered within nine months (270 days) of installation. DuPont requires that **DuPont™ Flashing Tape** be covered within four months (120 days) of installation.
- Ensure that window / door and flashing system design takes into account common factors that will impact performance, such as:
 - Climate considerations: Rainfall, Wind, Temperature (hot / cold cycles), Humidity
 - Building design: Window / Wall Design (overhangs, recessed openings, bump-outs), Wall Assembly (wood frame or masonry), Window System (wood or vinyl), New Construction or Replacement Window drainage path
 - UV exposure prior to the construction of the exterior facade
- Field testing the window/door and wall installation as a complete system is a recommended best practice.
- Use of trained installers is highly recommended.

Field Preparation of Recessed Window Corner Using DuPont™ FlexWrap™

The method illustrated in this installation guideline uses 6" wide FlexWrap™ to fabricate a Recessed Window Corner for a recess that is up to 2" deep with double stud framing. The same method can be used for recesses greater than 2", and up to 4" deep, which requires the use of 9" FlexWrap™. This installation guideline also applies to single stud framing which is limited to the use of 6" FlexWrap™ for fabrication of Recessed Window Corners. See summary of FlexWrap™ dimensions below and pictures to right for additional guidance.

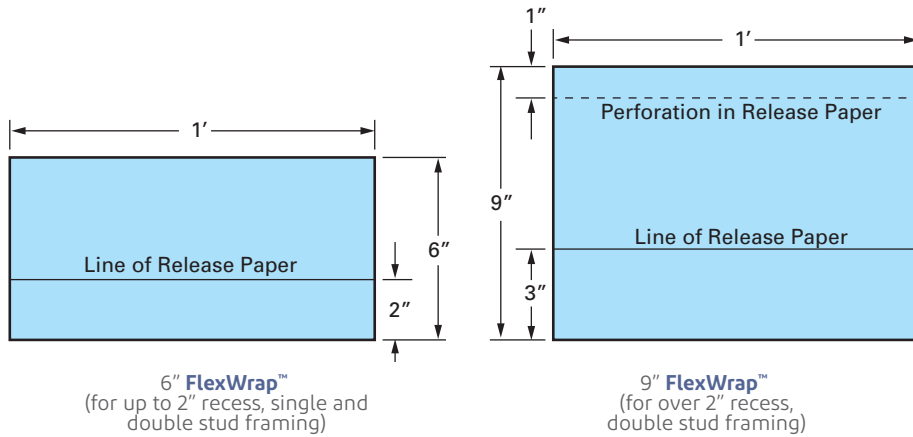

The following photos show the fabricated Recessed Window Corners for a recess that is up to 2" deep with double stud window framing using 6" FlexWrap™ (left) and a recess that is 4" deep with double stud window framing using 9" FlexWrap™ (right).

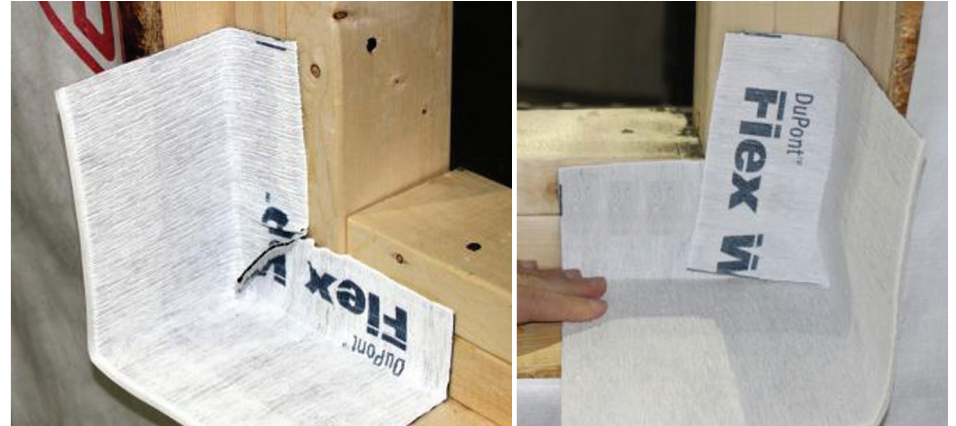

The pictures below show the 6" FlexWrap™ Recessed Window Corner installed on a single stud window. Note that the FlexWrap™ Recessed Window Corner extending slightly beyond the face of the stud (left) can be fully adhered into framing (right). See Step 4 for additional information.

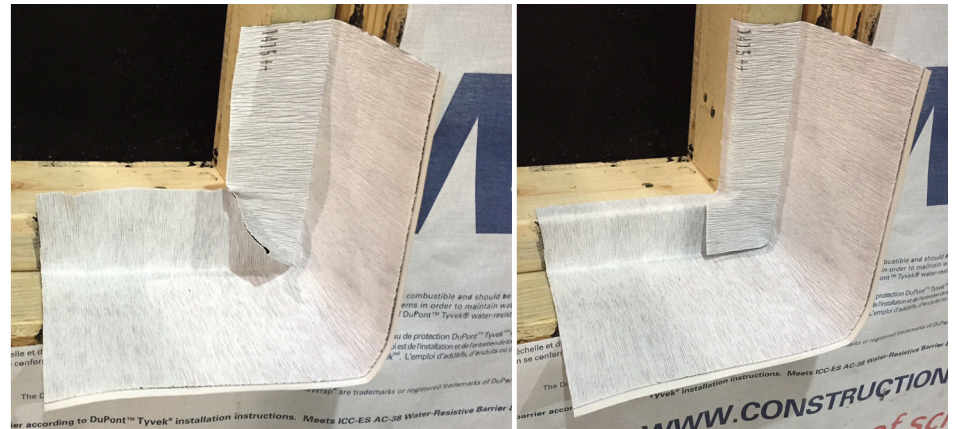

Fabricate four Recessed Window Corners



1. Cut Four 12" Pieces of 6" DuPont™ FlexWrap™



2. Create Horizontal CREASE A. Fold FlexWrap™ at release paper to break perforations and create crease.

NOTE: The narrow release paper will be used to guide corner fold in Step 5.



3. Create Vertical CREASE B. Fold FlexWrap™ in half, lengthwise, and create sharp crease at the fold.

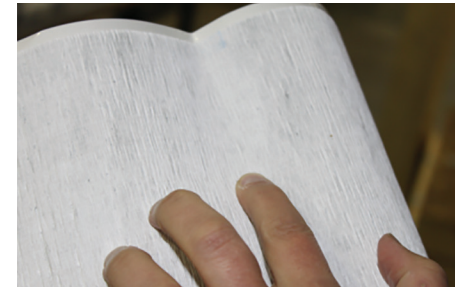

4. Set Corner Fold Width. Place index finger on the top side of the FlexWrap™ at the intersection of CREASE A and CREASE B.

NOTE: This will put pressure on the opposite side of release paper at the crease, and set the corner fold width.



5. Create Corner Fold. On the reverse side of the FlexWrap™, starting at the intersection of CREASE A and CREASE B, fold along CREASE B going out towards edge of narrow release paper.

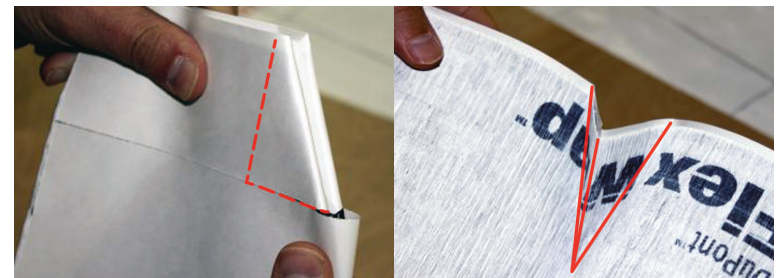

6. Crease Center Fold. Press firmly to create sharp crease in center and edges of fold. Sharp creases are necessary so the folds remain in the top sheet of the FlexWrap™ after release paper is removed.

Fabricate four Recessed Window Corners

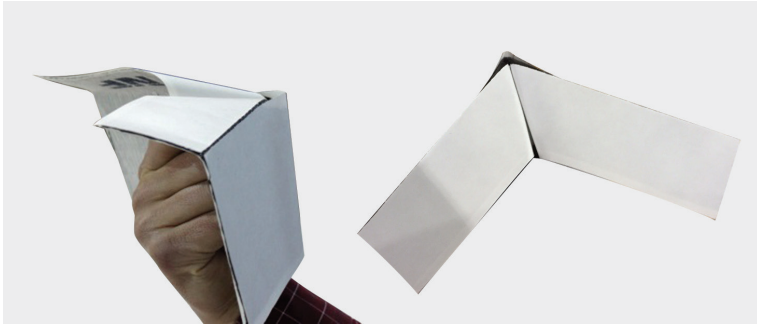

NOTE: Center crease should be sharp enough to assist in creating a ~90° fold between the two release papers at a right angle with vertical crease (Crease B), as shown below:



7. Form Recessed Window Corner. Remove narrow-width release paper and, using the creases made in Step 6, carefully press together the exposed butyl within the corner fold to create Recessed Window Corner. Repeat with the 3 remaining 12" pieces of DuPont™ FlexWrap™.

Alternative Method: Use the guide on page 27 of this document to create a reusable template using a piece of hard/rigid plastic. Once created, the template can be used to aid in removal of the release paper from the corner section only as indicated below. The template will be placed over the 12" piece of FlexWrap™ (release paper facing up) and aligned according to the applicable marks on the template. The release paper can then be torn along the edge of the template to expose the butyl. Alternatively, the template can be used to mark the release paper for removal. In this case a straight edge can be used to assist in tearing the release paper. **Do not cut the release paper with a knife or other sharp object** as this could result in damage to the butyl and compromise protection provided by the FlexWrap™ Recessed Window Corners.

Once the release paper is removed to create a triangular area of expose butyl, fold the FlexWrap™ according to Step 6 above to create the 90° corner and press exposed butyl together. Once the remaining narrow release paper is removed, the Recessed Window Corner is ready to install.

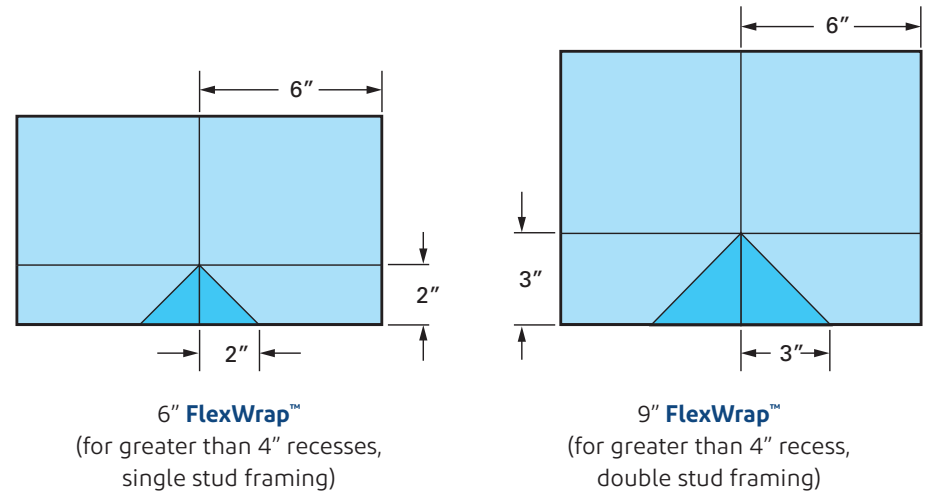

DuPont Self-Adhered Flashing Products – Installation Guidelines for Up to 4” Recess Using Single and Double Stud Window Framing

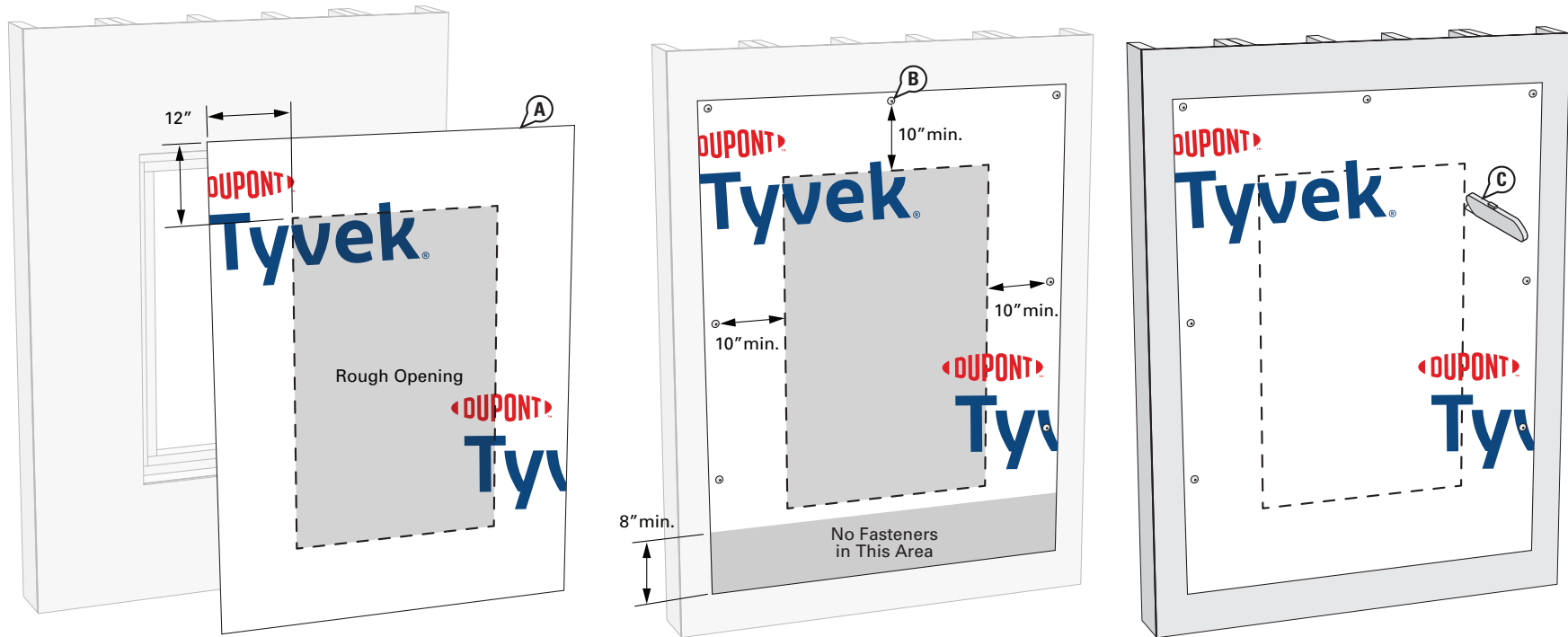

STEP 1

Install **DuPont™ Tyvek® WRB** Frame Around Window Rough Opening

Installation of **Tyvek® WRB** frame prior to window installation is necessary for proper shingling and integration with the **Tyvek® WRB** which will be installed after the window (see Step 12).

- A. Cut a piece of **Tyvek® WRB** that is 24" wider and 24" taller than the window rough opening to allow a 12" width around all sides.
- B. Center the piece of **Tyvek® WRB** over the rough opening and fasten along the sides and across the top using **DuPont™ Tyvek® Wrap Caps** or recommended fastening system. Fasteners should not be installed within 10" of the edge of the rough opening, and no fasteners should be installed within 8" of the bottom edge of the **Tyvek® WRB**.
- C. Cut an opening using an "O" cut at the perimeter of the rough opening along the dashed indicated lines to create a **Tyvek® WRB** frame around the window. (Ensure that the **Tyvek® WRB** frame is cut flush with the sheathing and is not wrapped into the rough opening).

DuPont Self-Adhered Flashing Products – Installation Guidelines for Up to 4” Recess Using Single and Double Stud Window Framing

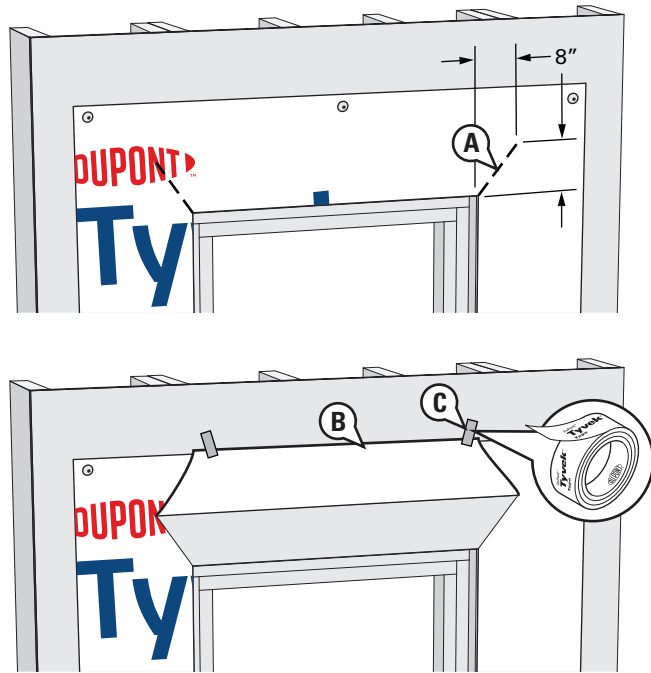

STEP 2

Prepare **DuPont™ Tyvek® WRB** Frame for Window Installation

Cut two 45 degree slits extending a minimum of 8” up and away from the top corners of the rough opening. This will create a flap to expose sheathing or framing members to allow head flashing installation.

- D. Flip the head flap up to expose the sheathing and temporarily secure with **DuPont™ Tyvek® Tape**.
- E. Temporarily secure the **Tyvek® WRB** frame with **Tyvek® Tape** around rough opening before flashing is installed to help facilitate flashing installation.

ALTERNATE METHOD TO SECURE HEAD FLAP: In lieu of temporarily taping, the head flap can be tucked under the **Tyvek® WRB**.

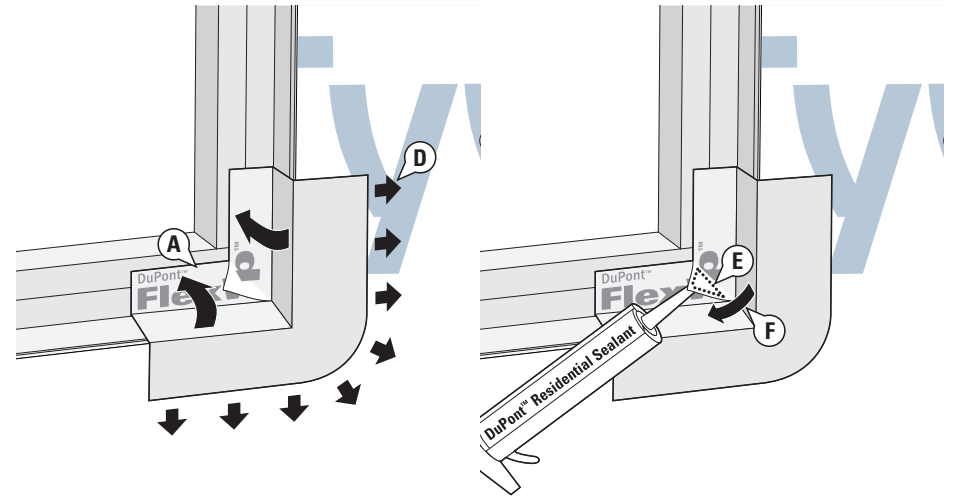

STEP 3

Install **DuPont™ FlexWrap™** Recessed Window Corner at Sill

- A. Place **FlexWrap™** Recessed Window Corner into corner of recess so exposed butyl is against face of recessed window frame and adhere.

NOTE: For double stud window frames, the **FlexWrap™** Recessed Window Corner should extend a minimum of 2” onto the face of the recessed window frame and cover the seams between the studs. For single stud window frames, the **FlexWrap™** Recessed Window Corner extending slightly beyond the face of the stud can be fully adhered into framing.

- B. Remove remaining release paper.
- C. Adhere exposed butyl to sill and jamb surfaces of recess.
- D. Fan **FlexWrap™** at bottom corners onto **Tyvek® WRB** frame on face of wall. Coverage of **FlexWrap™** should be 2” to 3” onto the face of the wall.
- E. Place a bead of **DuPont™ Residential Sealant** or recommended sealant behind the loose triangular flap within the **FlexWrap™** Recessed Window Corner.
- F. Press down the loose triangular flap onto the sealant.

DuPont Self-Adhered Flashing Products – Installation Guidelines for Up to 4” Recess Using Single and Double Stud Window Framing

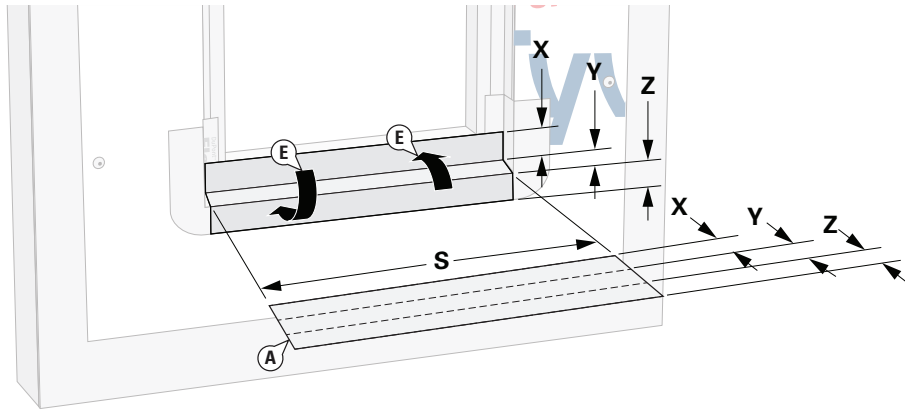

Table 1: Sill/Head Flashing for Shallow Recessed Flanged Window Condition

	X	Y	Z
6" DuPont™ Flashing Tape (single stud)	2"	1"	3"
6" DuPont™ Flashing Tape (single stud)	2"	2"	2"
6" DuPont™ Flashing Tape (double stud)	2"	2"	2"
9" DuPont™ Flashing Tape (double stud)	3"	3"	3"
9" DuPont™ Flashing Tape (double stud)	3"	4"	2"

STEP 4

Install **DuPont™ Flashing Tape** at Sill

Cut the **DuPont™ Flashing Tape** the length of the outer sill (S). Refer to Table 1 below to determine which width of **DuPont™ Flashing Tape** to use.

- G. Fold the **DuPont™ Flashing Tape** lengthwise using the measurements (X, Y and Z) shown in Table 1, creating sharp creases to help achieve sharp corners when release paper is removed.
- H. Remove the center piece of release paper by carefully tearing along the creases. Do not cut release paper with sharp object as this could result in damage to butyl and compromise protection provided by the **DuPont™ Flashing Tape**.
- I. Adhere exposed butyl to sill.
- J. Unfold unadhered flashing, remove remaining pieces of release paper and adhere butyl adhesive onto the face of the recessed window frame and onto the **DuPont™ Tyvek® WRB**.

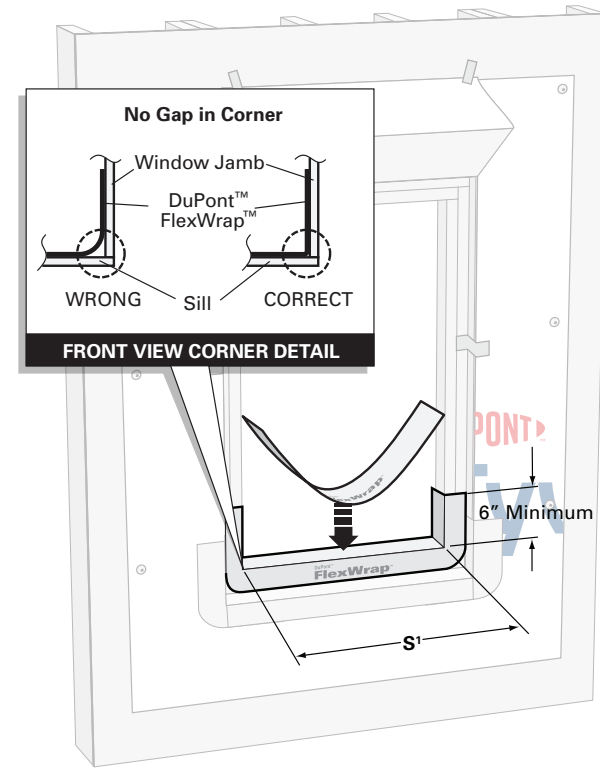

STEP 5

Install **DuPont™ FlexWrap™** in Rough Opening at Sill

- A. Cut **FlexWrap™** at least 12" LONGER than width of inner/recessed sill(S). Use roll widths sufficient to achieve a minimum of 1" adhesion BEYOND where the window frame will be located, ensuring 2"– 3" adhesion onto the face of the framing.
- B. Remove wide piece of release paper. Position on horizontal surface of inner/recessed sill by aligning the inside edge of the narrow release paper with the face of the framing to ensure 2"– 3" of the **FlexWrap™** will be adhered to the face of the framing and a minimum of 6" up each jamb. Adhere onto horizontal surfaces.
- C. Remove narrow release paper.
- D. Fan out **FlexWrap™** at bottom corners onto face of recessed window framing. Coverage of **FlexWrap™** should be 2"– 3" onto the face of the recessed window frame, extending beyond into the recess if necessary.

DuPont Self-Adhered Flashing Products – Installation Guidelines for Up to 4” Recess Using Single and Double Stud Window Framing

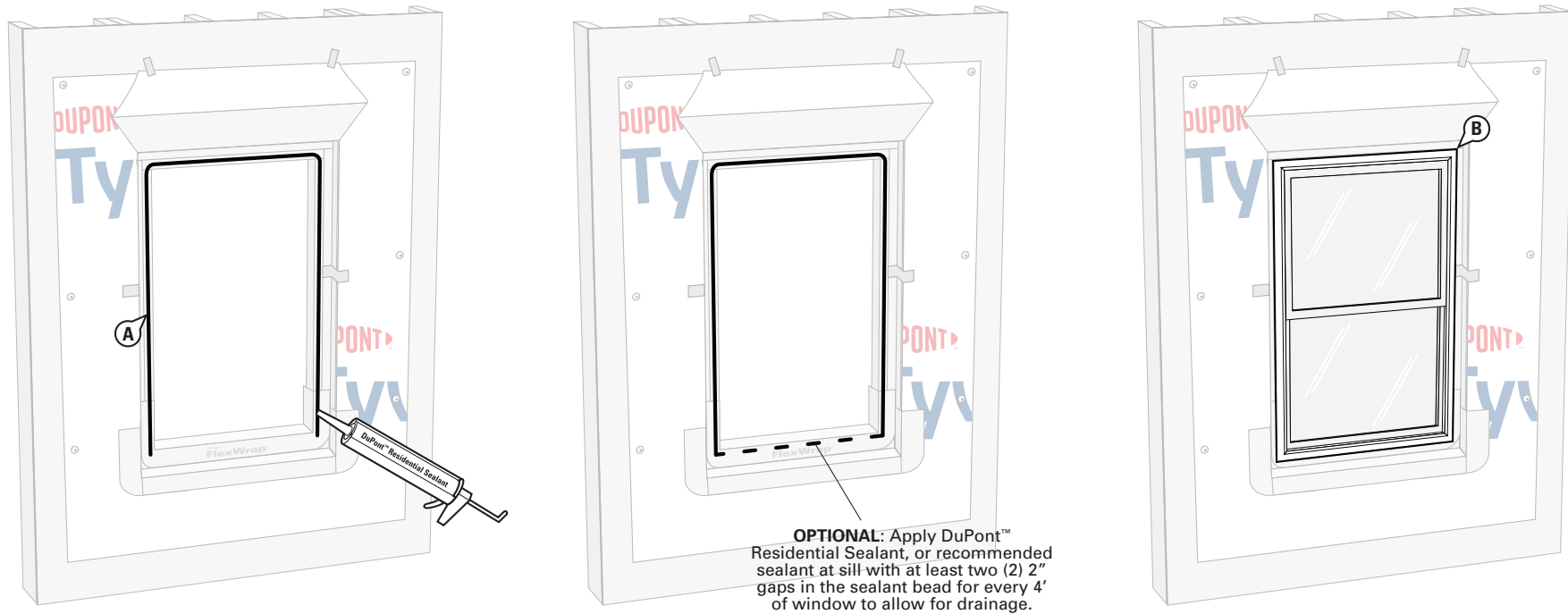

STEP 6

Install Window

A. Apply **DuPont™ Residential Sealant** or recommended sealant on three sides of the face of the inner recess framing at jambs and head as shown below.

B. Install window per window manufacturer’s instructions.

DuPont Self-Adhered Flashing Products – Installation Guidelines for Up to 4” Recess Using Single and Double Stud Window Framing

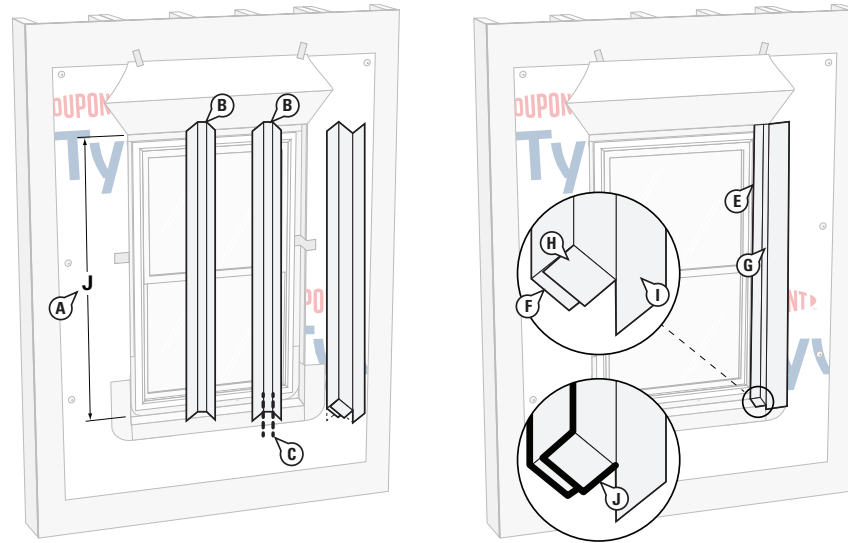

STEP 7

Install **DuPont™ Flashing Tape** at Jambs

- Cut a piece of **DuPont™ Flashing Tape** that is 2” LONGER than the length of the outer jamb (J).
- Fold the **DuPont™ Flashing Tape** lengthwise using the measurements (X, Y and Z) shown in Table 2 below, creating sharp creases to help achieve sharp corners when release paper is removed.
- Starting at the bottom, cut a 2” vertical slit in the **DuPont™ Flashing Tape** along each crease. This will be used to create the **DuPont™ Flashing Tape** corner that is created in Steps F and G shown below.

NOTE: Cut the first crease from the left edge of the **DuPont™ Flashing Tape** when preparing to apply to the right-hand jamb or the first crease from the right when preparing for the left-hand jamb.

Table 2: Jamb Flashing for Shallow Recessed Flanged Window Condition

	X	Y	Z
6” DuPont™ Flashing Tape (single stud)	2”	1”	3”
6” DuPont™ Flashing Tape (single stud)	2”	2”	2”
6” DuPont™ Flashing Tape (double stud)	2”	2”	2”
9” DuPont™ Flashing Tape (double stud)	3”	3”	3”
9” DuPont™ Flashing Tape (double stud)	3”	4”	2”

- Remove the first piece of release paper to expose the butyl that will be installed onto the window flange by tearing along the crease. Leave the release paper on the 2” flap created in Step C. Do not cut release paper with sharp object as this could result in damage to butyl and compromise protection provided by the **DuPont™ Flashing Tape**.
- Starting at top of window, adhere exposed butyl adhesive onto window flange.
- Remove the release paper from the corner flap in the **DuPont™ Flashing Tape**, created in Step C, and adhere the flap to the sill.
- Once the butyl is adhered to the window flange and sill, remove the center release paper – leaving the release paper on the 2” flap created in Step C. The flashing can now be adhered to the inside edge of the rough opening.
- Remove the release paper from the second corner flap and adhere over the first flap.
- Remove the remaining release paper and adhere the **DuPont™ Flashing Tape** onto the face of the wall and onto the **DuPont™ Tyvek® WRB**.
- Apply **DuPont™ Residential Sealant**, or recommended sealant, to the interfaces as shown at right.

NOTE: Keeping the remaining release papers intact will make the flashing more rigid to help maneuver the flashing into the corners.

- Repeat Steps A-J for opposite jamb.

DuPont Self-Adhered Flashing Products – Installation Guidelines for Up to 4” Recess Using Single and Double Stud Window Framing

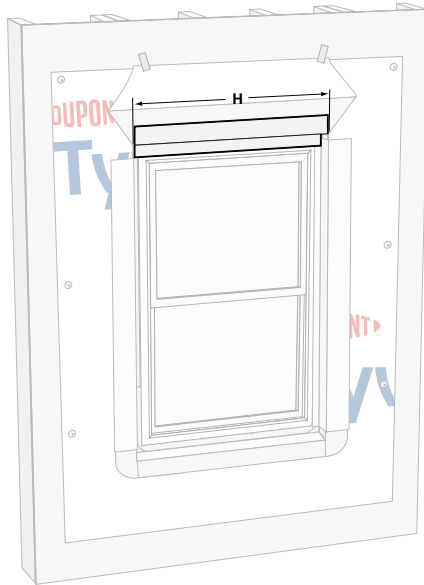

STEP 8

Install **DuPont™ Flashing Tape** at Head

- A. Cut a piece of **DuPont™ Flashing Tape** the length of the head rough opening “H”.
- B. Fold the **DuPont™ Flashing Tape** lengthwise using the measurements (X, Y and Z) determined in Step 4, creating sharp creases to help achieve sharp corners when release paper is removed.
- C. Remove the center release paper. The center piece of the release paper can be carefully removed by tearing along the creases, but do not cut release paper with sharp object as this could result in damage to butyl and compromise protection provided by the **DuPont™ Flashing Tape**.
- D. Adhere exposed butyl to recessed surface above window.
- E. Remove the outer pieces of release paper.
- F. Adhere exposed butyl over window head flange.
- G. Adhere last section of exposed butyl onto exterior sheathing.

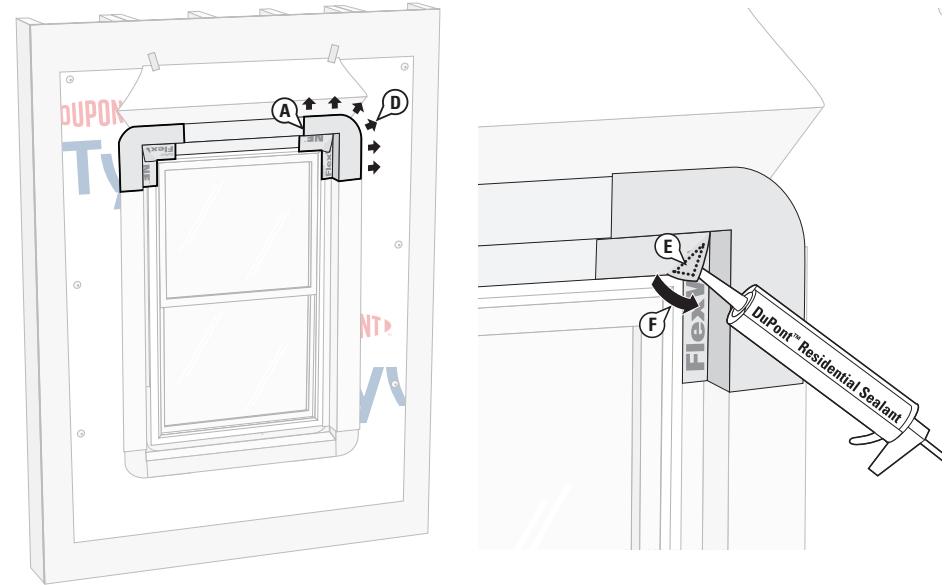

STEP 9

Install **DuPont™ FlexWrap™** Recessed Window Corners at Head

- A. Install **FlexWrap™** Recessed Window Corners into the upper corner of the window rough opening with exposed butyl adhered onto the window flanges in a similar manner used for lower corner pieces (See 3).
- B. Remove remaining release paper.
- C. Adhere exposed butyl to head and jamb surfaces of recess.
- D. Fan **FlexWrap™** Recessed Window Corners at upper corners onto face of wall. Coverage of **FlexWrap™** Recessed Window Corners should be 2” to 3” onto the face of the wall.
- E. Place a bead of **DuPont™ Residential Sealant** or recommended sealant inside the corner flaps behind the loose triangular flap of the corner piece.
- F. Press the loose triangular flap onto the sealant in the corner piece.
- G. Repeat Steps A-F for opposite corner.

DuPont Self-Adhered Flashing Products – Installation Guidelines for Up to 4” Recess Using Single and Double Stud Window Framing

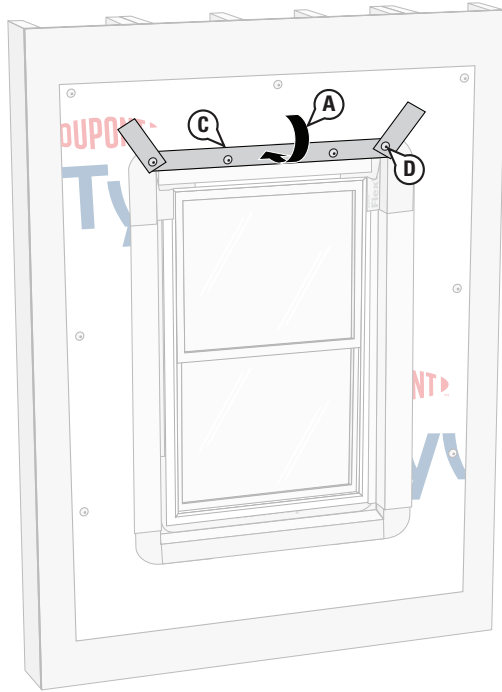

STEP 10

Secure Upper Flap

- Flip down upper flap of **DuPont™ Tyvek® WRB** so it lays flat across head flashing.
- Cut ~1” strip of the **Tyvek® WRB** at lower horizontal edge of head flap.
- Continuous tape seams as shown with **DuPont™ Flashing Tape**. Skip-taping at head is acceptable if an air barrier is not required or if additional drainage is desired.
- Install mechanical fasteners through the flashing at the head flap.

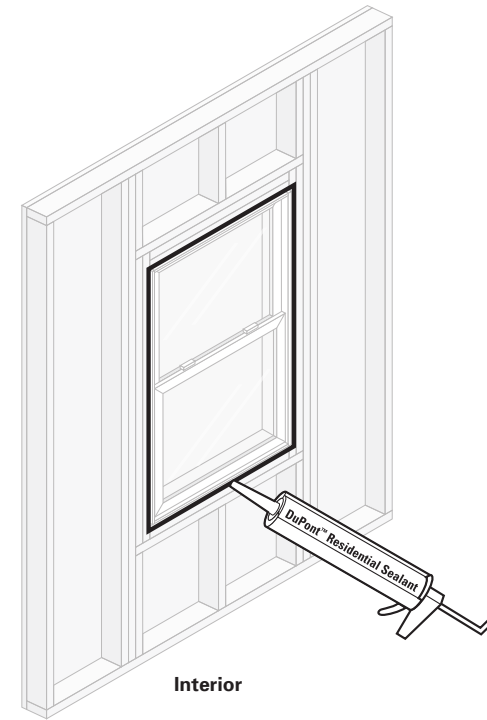

STEP 11

Seal Interior Opening

Install **DuPont™ Residential Sealant** or recommended sealant (and backer rod as necessary) around the window opening at the interior. It is also acceptable to use **DuPont™ Window & Door Foam**, **Great Stuff Pro™ Window & Door Polyurethane Foam Sealant**, or recommended foam. When using **DuPont™ Residential Sealant**, tool sealant bead flat to allow the natural curing process to create a concave shape. Be sure that the sealant penetrates the grooves of the **DuPont™ FlexWrap™** around the sill. When using **Great Stuff Pro™ Window & Door Polyurethane Foam Sealant** in perimeter openings less than 1/2”, apply using the plastic extension tip for the **Great Stuff Pro™ Dispensing Gun** during installation.

NOTE: Installations that specify a window/door design rating of DP45 or greater require extra precautions. See General Instructions for performance requirements exceeding this design rating.

DuPont Self-Adhered Flashing Products – Installation Guidelines for Up to 4” Recess Using Single and Double Stud Window Framing

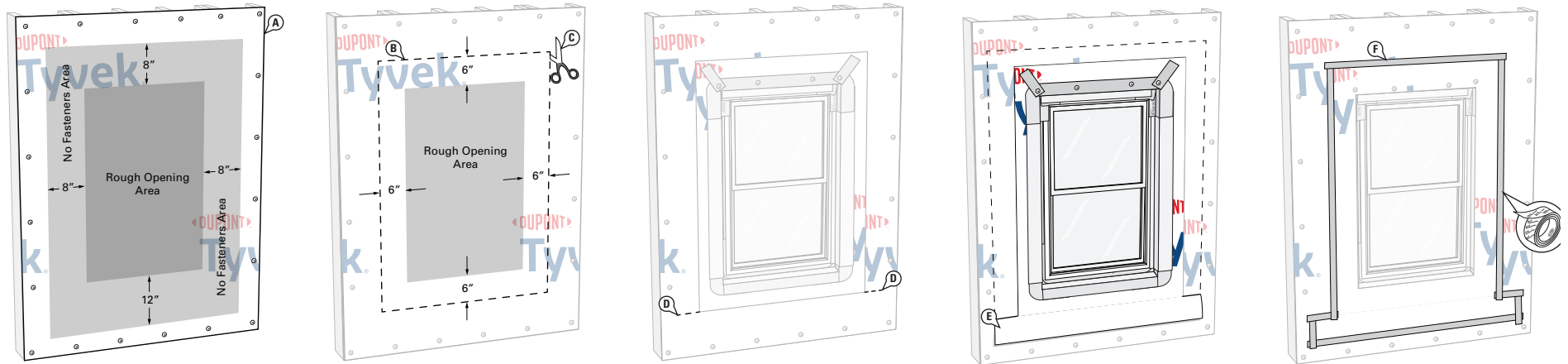

STEP 12

Install and Integrate DuPont™ Tyvek® WRB

- A. Install the **Tyvek® WRB** according to the *DuPont™ Tyvek® Air- and Water-Resistive Barrier Installation Guidelines*. Do not install fasteners within 8” of the rough opening along jambs and head and within 12” along the sill.
- B. Mark a perimeter box 6” away from the rough opening sill, jambs and head.
- C. Cut the **Tyvek® WRB** along perimeter marking to expose window and **Tyvek® WRB** frame below. Do not cut **Tyvek® WRB** frame underneath.
- D. Create 6” horizontal slits in the **Tyvek® WRB** at each lower corner of the perimeter cut.
- E. Bring the bottom portion of the **Tyvek® WRB** frame through the slits so it laps over the top layer of **Tyvek® WRB**.
- F. Tape seams at bottom, sides, and top of rough opening using **DuPont™ Tyvek® Tape**.

Corner Release Paper Removal Guide for Alternative Method described on page 6

Use the following guide to create a template to aid in removal of the release paper from the corner section only. This will assist in creating the 90° fold between the two release papers.

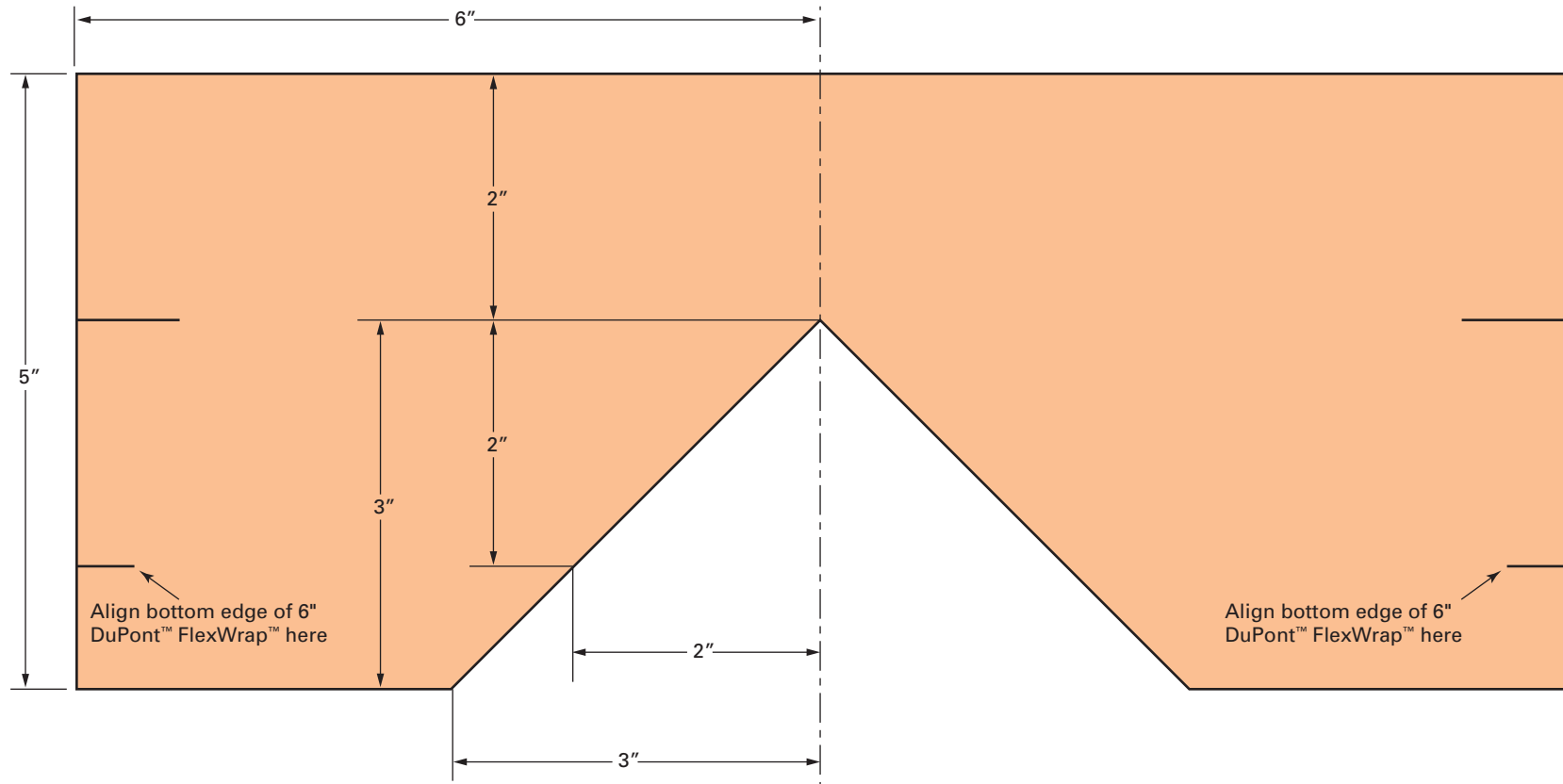

Align the bottom edge of 6" **DuPont™ FlexWrap™** with the the 2" marks (for up to 2" recess). Align the bottom edge of 9" **FlexWrap™** with the lower edge of the template (for recesses greater than 2").

For best results, create a reusable template using a piece of heavy/rigid plastic. The template can also be used as a guide when tearing the release paper. Otherwise, use the template to mark the release paper and then use a metal straight edge to assist in tearing the release paper. **Do not cut the release paper with a knife or other sharp object** as this could result in damage to the butyl and compromise protection provided by the **FlexWrap™** Recessed Window Corners.

Technical Specifications

DuPont Self-Adhered Flashing Products are made from a synthetic rubber adhesive and a laminate of polyethylene film, polypropylene film, elastic fiber, synthetic rubber adhesive, polyurethane adhesive, and a top sheet of flash spunbonded high density polyethylene fibers or polypropylene film. Additives have been incorporated into these materials to provide ultraviolet light resistance. DuPont requires that **DuPont™ FlexWrap™**, **DuPont™ FlexWrap™ EZ**, and **DuPont™ StraightFlash™** be covered within nine months (270 days) of installation. DuPont requires that **DuPont™ Flashing Tape** be covered within four months (120 days) of installation.

Warning

DuPont Self-Adhered Flashing Products and their release paper are slippery and should not be walked on. Remove release paper from work area immediately. **DuPont Self-Adhered Flashing Products** will melt at temperatures greater than 250°F (121°C). **DuPont Self-Adhered Flashing Products** are combustible and should be protected from flames and other high heat sources. **DuPont Self-Adhered Flashing Products** will not support combustion if the heat source is removed. However, if burning occurs, ignited droplets may fall away from the point of ignition. For more information, call 1-800-44-Tyvek.

DuPont™ Residential Sealant is irritating to skin, eyes, and respiratory tract. For proper usage, follow directions stated on the product label. For health information, refer to the Material Safety Data Sheet or call Chemtrec at 1-800-424-9300.

Caution

When cured, **Great Stuff Pro™ Window & Door Polyurethane Foam Sealant** is combustible and will burn if exposed to open flame or sparks from high-energy sources. Do not expose to temperatures above 240°F (116°C). For more information, consult (Material) Safety Data Sheet ((M)SDS), call Dow at 1-866-583-BLUE (2583) or contact your local building inspector. In an emergency, call 1-989-636-4400 in the U.S. or 1-519-339-3711 in Canada. When air sealing buildings, ensure that combustion appliances, such as furnaces, water heaters, wood burning stoves, gas stoves and gas dryers are properly vented to the outside. See website: <http://www.epa.gov/iaq/homes/hip-ventilation.html>.

In Canada visit: <http://archive.nrc-cnrc.gc.ca/eng/ibp/irc/bsi/83-house-ventilation.html>.

Great Stuff Pro™ polyurethane foam sealant and adhesive products contain isocyanate and a flammable blowing agent. Read all instructions and (Material) Safety Data Sheet ((M)SDS), carefully before use. Eliminate all sources of ignition before use. Cover all skin. Wear long sleeves, gloves, and safety glasses or goggles. Not for use in aviation, or food/beverage contact, or as structural support in marine applications. Provide adequate ventilation or wear proper respiratory protection. Contents under pressure. Not to be used for filling closed cavities or voids such as behind walls and under tub surrounds; this improper use of the product could result in the accumulation of flammable vapors and/or uncured material. Failure to follow the warnings and instructions provided with the product, and/or all applicable rules and regulations, can result in injury or death.

Building and/or construction practices unrelated to building materials could greatly affect moisture and the potential for mold formation. No material supplied by Dow can give assurance that mold will not develop in any specific system.

Read all instructions and (Material) Safety Data Sheet ((M)SDS) carefully before use.

Note

When installed in conjunction with other building materials, **DuPont Self-Adhered Flashing Products** must be properly shingled with these materials such that water is diverted to the exterior of the wall system. **DuPont™ Tyvek®** products are air and water barriers and not the primary water barrier. The outer facade is the primary barrier. You must follow facade manufacturer's installation and maintenance requirements for all facade systems in order to maintain water holdout properties and ensure performance of **DuPont™ Tyvek® WRBs**. Use of additives, coatings or cleansers on or in the facade system may impact the performance of **Tyvek® WRBs**. DuPont Performance Building Solutions products are to be used as outlined in this installation guideline. **DuPont Self-Adhered Flashing Products** should only be used to seal penetrations and flash openings in houses or buildings. **DuPont Self-Adhered Flashing Products** are not to be used in roofing applications. For superior protection against bulk water penetration, DuPont suggests a system combining a quality exterior facade, a good secondary air and water barrier and exterior sheathing, high quality windows

and doors, and appropriate flashing materials paying attention to proper installation of each component. In a system where no exterior sheathing is used and **Tyvek® WRBs** are installed directly over the wall studs, exterior facade materials should be selected to ensure maximum protection against water intrusion. Careful workmanship and proper installation of each component is very important.

DuPont believes this information to be reliable and accurate. The information may be subject to revision as additional experience and knowledge is gained. It is the user's responsibility to determine the proper construction materials needed.

For complete warranty information please visit building.dupont.com or call 1-800-448-9835.

This information is not intended to be used by others for advertising, promotion, or other publication for commercial purposes.



For more information about
DuPont Performance Building Solutions,
please call 1-800-448-9835 or visit us at
building.dupont.com

© 2020 DuPont. DuPont™, the DuPont Oval Logo, and all trademarks and service marks denoted with ™, SM or ® are owned by affiliates of DuPont de Nemours, Inc. unless otherwise noted.

43-D100691-enNA-0320