

STEP 10

- A. CUT DUPONT™ FLEXWRAP™ NF AT LEAST 12" LONGER THAN WIDTH OF INNER RECESSED SILL. REMOVE WIDE PIECE OF RELEASE PAPER.
- B. COVER SILL BY ALIGNING FLEXWRAP™ WITH INSIDE EDGE OF SILL AND ADHERE ONTO SILL AND UP JAMBS (MIN. 6" ON EACH SIDE).
- C. REMOVE NARROW PIECE OF RELEASE PAPER.
- D. FAN OUT FLEXWRAP™ NF AT BOTTOM CORNERS ONTO FACE OF RECESSED WINDOW FRAMING. COVERAGE OF FLEXWRAP™ NF SHOULD BE A MINIMUM OF 2" ONTO THE FACE OF THE WINDOW FRAME.

STEP 9

- A. CUT THE LAST LAYER OF DUPONT™ FLASHING TAPE THE LENGTH OF THE OUTER WINDOW SILL AND USE APPROPRIATE WIDTH FOR A MIN. OF 2" ADHESION OF BUTYL ONTO FACE OF THE STUD FRAMING AT THE WINDOW SILL MAINTAINING A 2" OVERLAP ONTO PREVIOUS LAYER. FOLD TO CREATE A SHARP CREASE THAT IS ALIGNED WITH THE INTERSECTION OF THE RECESSED SILL AND THE FACE OF THE STUD FRAMING. TEAR RELEASE PAPER AT THE FOLD SO EXPOSED BUTYL CAN BE ADHERED ON TO SILL OF RECESS.
- B. ADHERE EXPOSED BUTYL ON SILL OF RECESS AND TIGHT INTO THE INTERSECTION OF RECESSED SILL AND FACE OF STUD FRAMING.
- C. REMOVE SECOND RELEASE PAPER AND ADHERE EXPOSED BUTYL ONTO FACE OF STUD FRAMING.
- D. APPLY A CONTINUOUS BEAD OF DUPONT™ RESIDENTIAL SEALANT OR RECOMMENDED SEALANT ALONG THE EDGE OF THE OVERLAP BETWEEN THE DUPONT™ FLASHING TAPE AND THE DUPONT™ FLEXWRAP™ NF.
- E. REMOVE THE RELEASE PAPER AND ALIGN ON SILL TO OVERLAP DUPONT™ FLEXWRAP™ NF BY 2" AND EXTEND UP EACH JAMB WALL OF RECESS 6". FLASHING TAPE SHOULD BE INSTALLED TIGHTLY INTO CORNER AT THE INTERSECTION OF THE RECESS SILL AND WALL OF RECESS.

STEP 8

- A. CUT THE FIRST COURSE OF DUPONT™ FLASHING TAPE 12" LONGER THAN OUTER SILL.
- B. REMOVE THE RELEASE PAPER AND ALIGN ON SILL TO OVERLAP DUPONT™ FLEXWRAP™ NF BY 2" AND EXTEND UP EACH JAMB WALL OF RECESS 6". FLASHING TAPE SHOULD BE INSTALLED TIGHTLY INTO CORNER AT THE INTERSECTION OF THE RECESS SILL AND WALL OF RECESS.

STEP 7

- A. CUT DUPONT™ FLEXWRAP™ NF AT LEAST 12" LONGER THAN WIDTH OF OUTER SILL OF RECESS.
- B. REMOVE WIDE PIECE OF RELEASE PAPER COVER HORIZONTAL SILL BY ALIGNING THE EXPOSED BUTYL ONTO THE HORIZONTAL SURFACE OF THE OUTER SILL AND UP JAMBS (MIN. 6" ON EACH SIDE).
- C. REMOVE NARROW RELEASE PAPER.
- D. FAN OUT FLEXWRAP™ NF AT BOTTOM CORNERS ONTO FACE OF WALL. COVERAGE OF FLEXWRAP™ NF SHOULD BE A MIN. OF 2" ONTO THE FACE OF THE WALL.

STEP 6

- A. PLACE DUPONT™ FLEXWRAP™ NF RECESSED WINDOW CORNER INTO OPENING SO EXPOSED BUTYL IS ADHERED AGAINST THE FACE OF RECESSED FRAMING REMOVE REMAINING RELEASE PAPER.
- B. ADHERE EXPOSED BUTYL TO SILL AND JAMB SURFACES OF RECESS.
- C. PLACE A BEAD OF DUPONT™ RESIDENTIAL SEALANT OR RECOMMENDED SEALANT BEHIND THE LOOSE TRIANGULAR FLAP WITHIN FLEXWRAP™ NF RECESSED WINDOW CORNER.
- D. PRESS DOWN THE LOOSE TRIANGULAR FLAP ONTO THE SEALANT.
- E. REPEAT STEPS A-E FOR OPPOSITE SIDE.

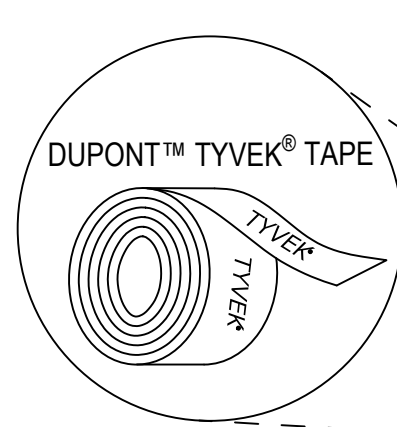

STEP 5

- A. FLIP THE CUT HEAD FLAP UPWARD TO EXPOSE THE SHEATHING AND TEMPORARILY SECURE WITH DUPONT™ TYVEK® TAPE.

STEP 4

- A. CUT AN OPENING IN THE DUPONT™ TYVEK® WRB ALONG THE PERIMETER OF THE ROUGH OPENING.
- B. ENSURE THE DUPONT™ TYVEK® WRB IS CUT FLUSH WITH THE SHEATHING AND IS NOT WRAPPED INTO THE ROUGH OPENING.
- C. CUT A HEAD FLAP AT A 45 ANGLE TO EXPOSE 8" OF SHEATHING TO ALLOW FOR HEAD FLASHING INSTALLATION.

STEP 3

- A. CUT A PIECE OF DUPONT(TM) TYVEK(R) WRB THAT IS 24" TALLER AND 24" WIDER THAN THEN ROUGH OPENING OF THE WINDOW.
- B. CENTER THE PIECE OVER THE ROUGH OPENING AND FASTEN ALONG THE SIDES AND TOP (LEAVE BOTTOM UN-FASTENED). DUPONT(TM) WRAP CAP FASTENERS TO BE PLACED MIN. 10" AWAY FROM THE ROUGH OPENING EDGE.

STEP 2

- A. SHEATHING TO BE INSTALLED OVER BARE STUDS.
- B. AFTER SHEATHING HAS BEEN INSTALLED, CUT AN OPENING IN THE SHEATHING ALONG THE PERIMETER OF THE ROUGH OPENING FOR WINDOW.
- C. ENSURE THE SHEATHING IS CUT FLUSH WITH OR SLIGHTLY BELOW THE SILL FRAMING TO ALLOW FOR POSITIVE DRAINAGE.

STEP 1

- A. BARE STUDS PRIOR TO SHEATHING INSTALLATION. SLOPE SILL FRAMING TO EXTERIOR. FRAMING AND NON-WATERPROOFING COMPONENTS ARE ONLY SHOWN SCHEMATICALLY. SEE DRAWINGS BY OTHERS FOR DETAILED INFORMATION.

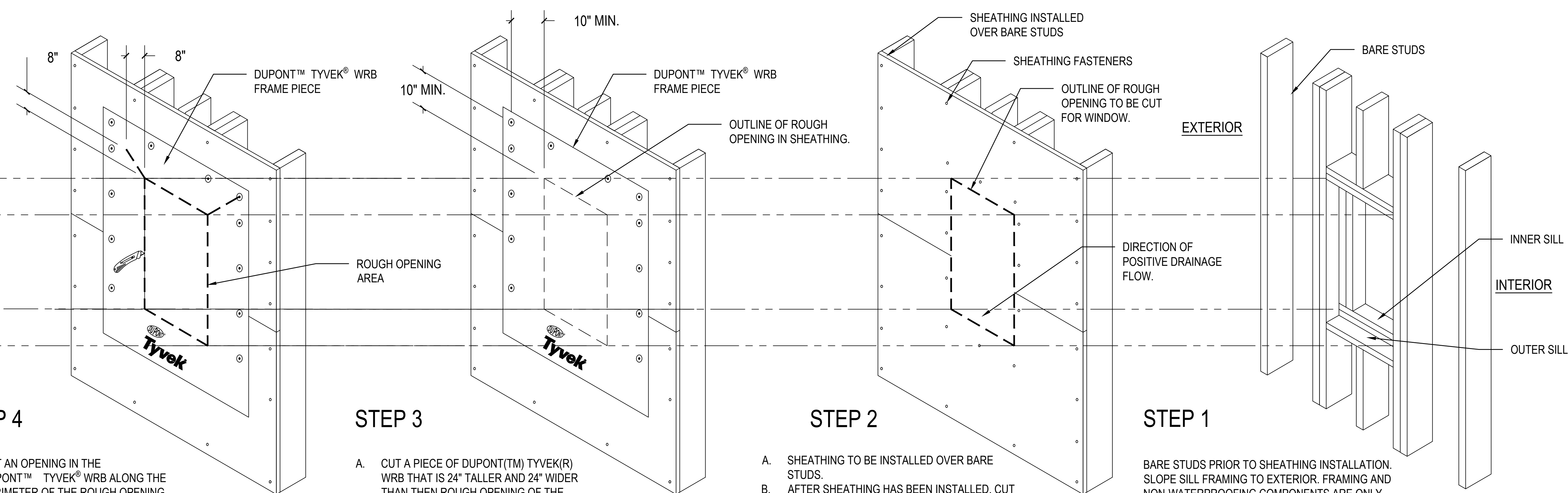

- NOTES:**
- FOR ADDITIONAL INFORMATION REGARDING PRODUCT INSTALLATION AND/OR FABRICATION INSTRUCTIONS FOR RECESSED WINDOW CORNERS, REFER TO THE APPLICABLE DUPONT™ SELF-ADHERED FLASHING SYSTEMS PRODUCTS INSTALLATION GUIDELINE.
 - INSTALLATION IS APPLICABLE FOR BUILDINGS LESS THAN 5 STORIES AND LOW-RISE MULTI-FAMILY RESIDENTIAL BUILDINGS LESS THAN 6 STORIES WHEN PERFORMANCE REQUIREMENTS DO NOT EXCEED ASTM E1677 (65 MPH EQUIVALENT STRUCTURAL LOAD AND 15 MPH EQUIVALENT WIND-DRIVEN RAIN WATER INFILTRATION), AND WINDOW/DOOR DESIGN RATINGS THAT DO NOT EXCEED DP45.

Integral Flanged Window Recessed Greater Than 4" Before WRB Installation Sequence - Method 2

DRAWING:
REVISION DATE: 11/12/2016
 R-OP-2180.2-MA, Page 1 of 3
 SCALE: Not to Scale



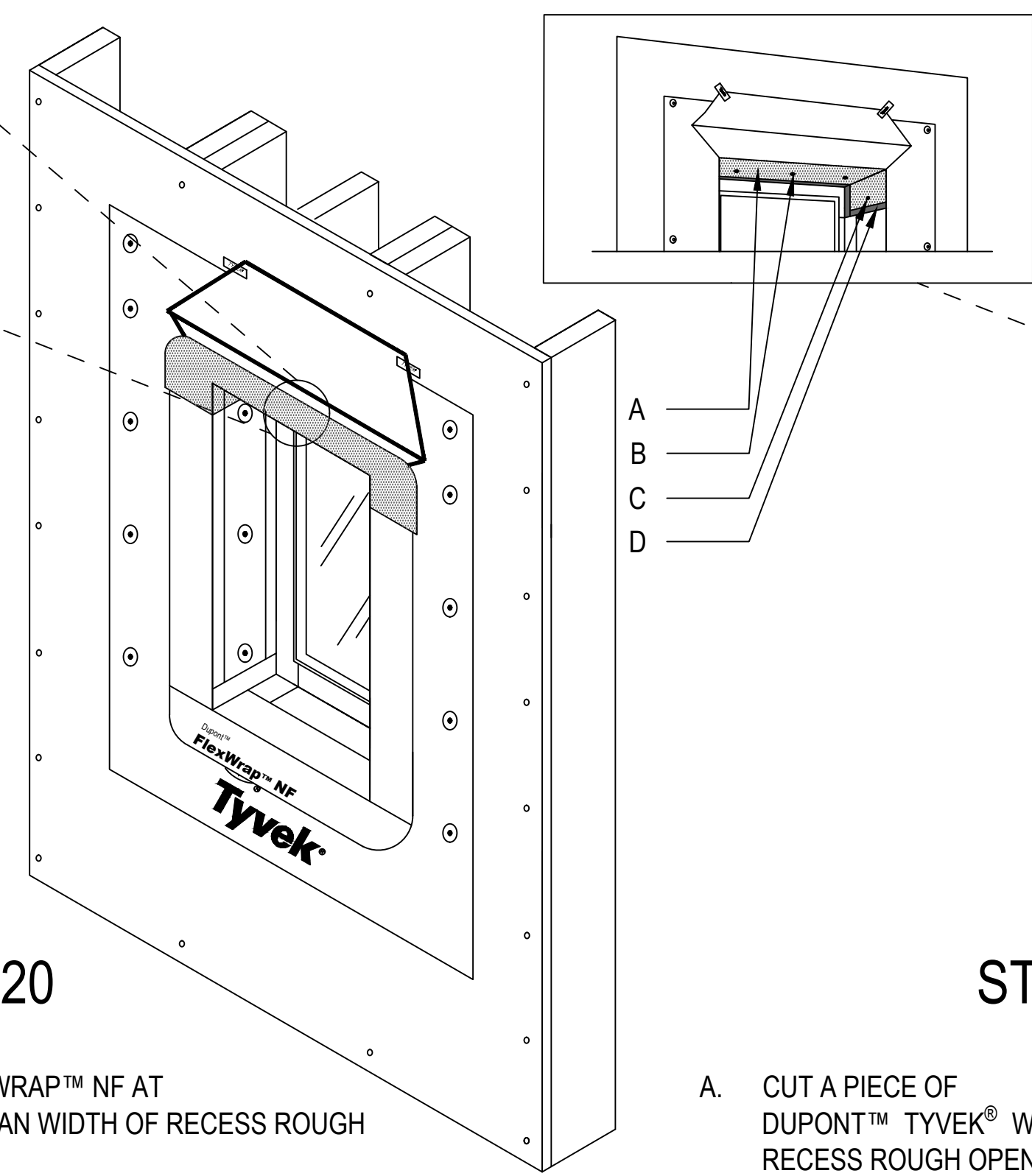
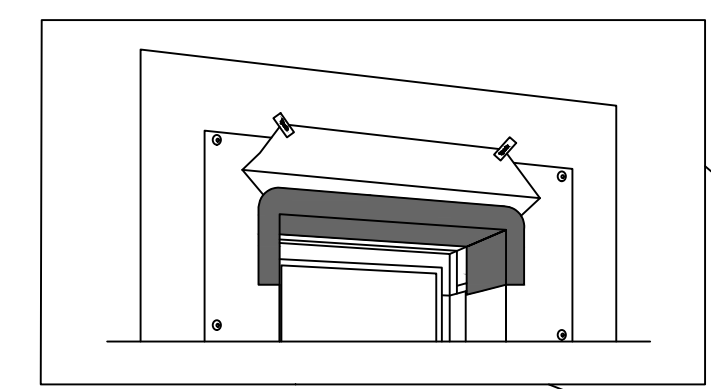

STEP 20

- A. CUT DUPONT™ FLEXWRAP™ NF AT LEAST 12" LONGER THAN WIDTH OF RECESS ROUGH OPENING.
- B. REMOVE WIDE PIECE OF RELEASE PAPER.
- C. ALIGN THE EXPOSED BUTYL WITH THE OUTSIDE EDGE OF THE WALL AND ADHERE TO THE HORIZONTAL SURFACE AT INNER CEILING OF HEAD RECESS AND DOWN INNER JAMB WALLS BY 6".
- D. REMOVE SECOND RELEASE PAPER.
- E. FAN OUT FLEXWRAP™ NF AT TOP CORNERS OF RECESS OPENING WITH MIN. COVERAGE OF 2" ONTO THE FACE WALL.

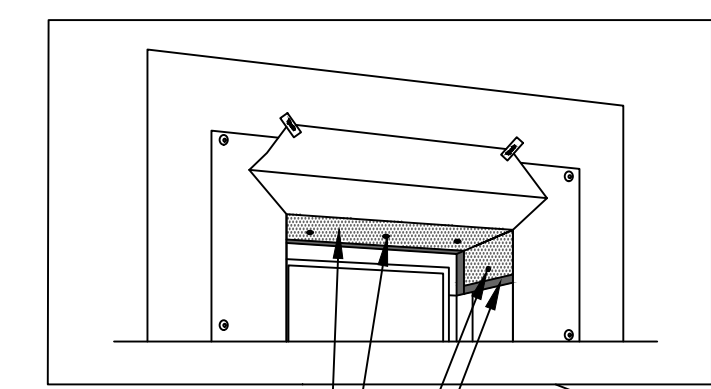

STEP 19

- A. CUT A PIECE OF DUPONT™ TYVEK® WRB 12" LONGER THAN RECESS ROUGH OPENING AND WIDTH 1 - 2" LESS THAN DEPTH OF THE RECESS.
- B. FASTEN AT RECESS CEILING SO OUTER EDGE IS ALIGNED WITH FACE OF THE WALL AND 6" OVERLAPS ONTO JAMB WALLS. DO NOT FASTEN WITHIN 3" OF EDGES SO DUPONT™ TYVEK® WRB CAN BE SEALED TO HEAD FLASHING USING DUPONT™ TYVEK® TAPE WITHOUT FASTENER INTERFERENCE.
- C. FASTEN AT JAMB WALLS OF RECESS. DO NOT FASTEN WITHIN 3" OF EDGES.
- D. SEAL ALL INSIDE EDGES USING DUPONT™ TYVEK® TAPE.

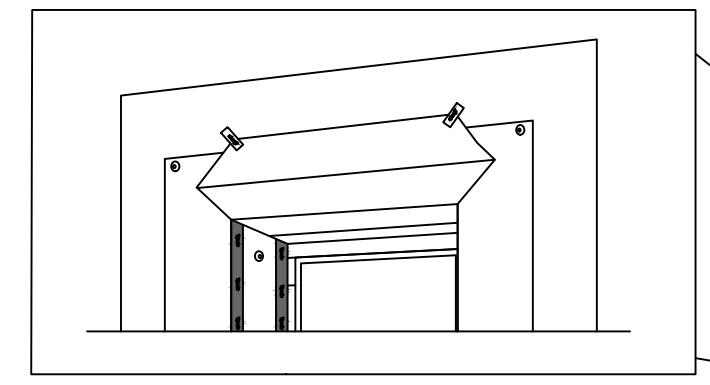

STEP 18

DUPONT™ TYVEK® TAPE
DUPONT™ FLASHING TAPE

- A. INSTALL DUPONT™ FLASHING TAPE ALONG THE BOTTOM OF DUPONT™ TYVEK® WRB INSIDE RECESS.
- B. SEAL VERTICAL EDGES OF DUPONT™ TYVEK® WRB USING DUPONT™ TYVEK® TAPE.
- C. REPEAT ON OPPOSITE SIDE.

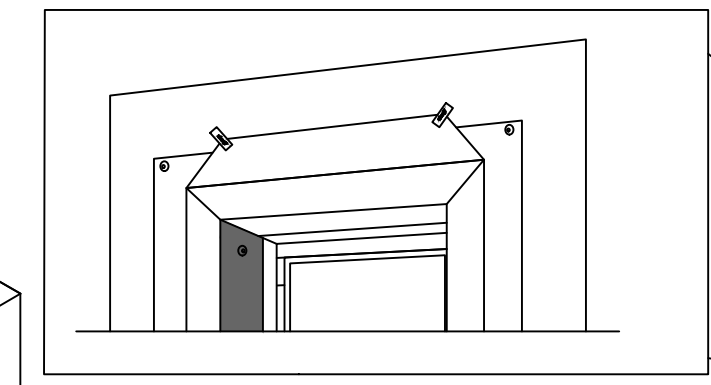

STEP 17

- A. CUT A PIECE OF DUPONT™ TYVEK® WRB FOR EACH RECESS JAMB THAT IS 2" LESS THAN THE HEIGHT (J) AND THE DEPTH OF THE ROUGH OPENING. (NOTE: THESE DIMENSIONS WILL NEED TO BE ADJUSTED ACCORDINGLY TO ACCOMMODATE THE SLOPE OF THE RECESS SILL).
- B. ALIGN FIRST PIECE OF DUPONT™ TYVEK® WRB WITH TOP OF RECESS AND CENTERED ON THE VERTICAL WALL. DO NOT FASTEN WITHIN 3" OF VERTICAL AND HORIZONTAL EDGES SO DUPONT™ TYVEK® WRB PATCH CAN BE SEALED TO FLASHING USING DUPONT™ TYVEK® TAPE WITHOUT FASTENER INTERFERENCE.

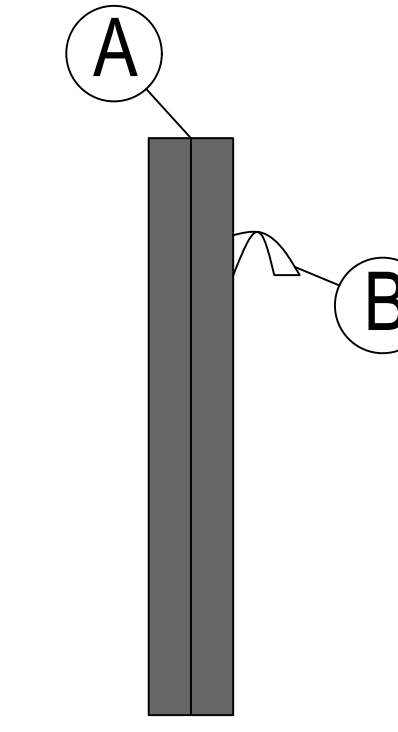

STEP 16

- A. CUT A PIECE OF DUPONT™ FLASHING TAPE THE LENGTH OF THE JAMB ROUGH OPENING AND FOLD LENGTHWISE CREATING A SHARP CREASE IN THE RELEASE PAPER.
- B. REMOVE ONE PIECE OF RELEASE PAPER BY TEARING ALONG THE CREASE, BUT DO NOT CUT RELEASE PAPER WITH SHARP OBJECT AS THIS COULD RESULT IN DAMAGE TO BUTYL AND COMPROMISE PROTECTION PROVIDED BY THE DUPONT™ FLASHING TAPE.
- C. ADHERE EXPOSED BUTYL ONTO FACE OF WALL SO CREASE IS ALIGNED WITH EDGE OF OUTER RECESS ROUGH OPENING.
- D. REMOVE REMAINING RELEASE PAPER AND ADHERE EXPOSED BUTYL INTO ROUGH OPENING OF RECESS.
- E. REPEAT STEPS A-D ON OPPOSITE SIDE.

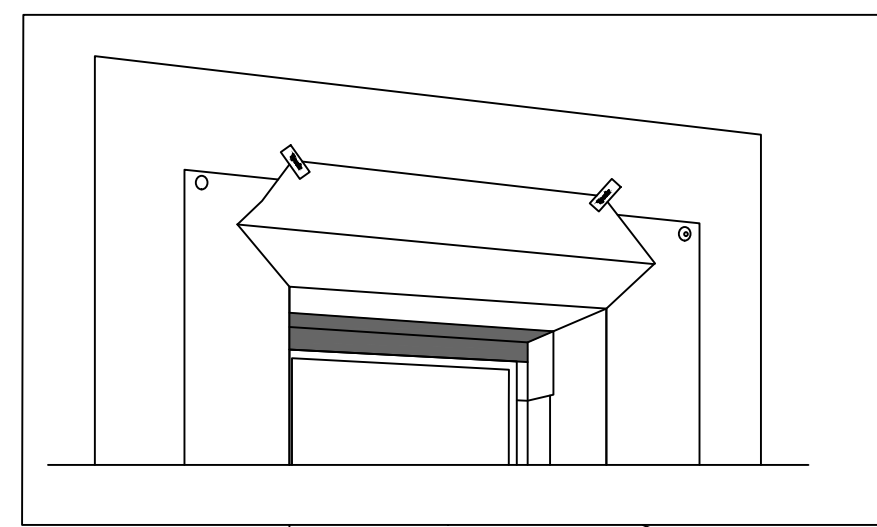

STEP 15

- A. CUT A PIECE OF DUPONT™ FLASHING TAPE THE LENGTH OF THE HEAD ROUGH OPENING. USE APPROPRIATE WIDTH OF DUPONT™ FLASHING TAPE TO OVERLAP WINDOW FLANGE. ADHERE ONTO FACE OF STUD FRAME, AND EXTEND A MIN. OF 2" ONTO CEILING OF RECESS.
- B. FOLD LENGTHWISE TO CREATE A SHARP CREASE IN THE RELEASE PAPER THAT IS ALIGNED WITH THE INTERSECTION OF THE FACE OF THE STUD FRAMING AND CEILING OF RECESS.
- C. REMOVE RELEASE PAPER BY TEARING ALONG THE FOLD TO EXPOSE BUTYL FOR INSTALLATION ONTO THE WINDOW FLANGE AND FACE OF STUD FRAMING. DO NOT CUT RELEASE PAPER WITH SHARP OBJECT AS THIS COULD RESULT IN DAMAGE TO BUTYL AND COMPROMISE PROTECTION PROVIDED BY THE DUPONT™ FLASHING TAPE.
- D. ADHERE ONTO WINDOW FLANGE AND TIGHTLY INTO CORNER OF INTERSECTION BETWEEN FACE OF STUD FRAMING AND CEILING OF RECESS.
- E. REMOVE REMAINING RELEASE PAPER AND ADHERE ONTO CEILING OF RECESS.

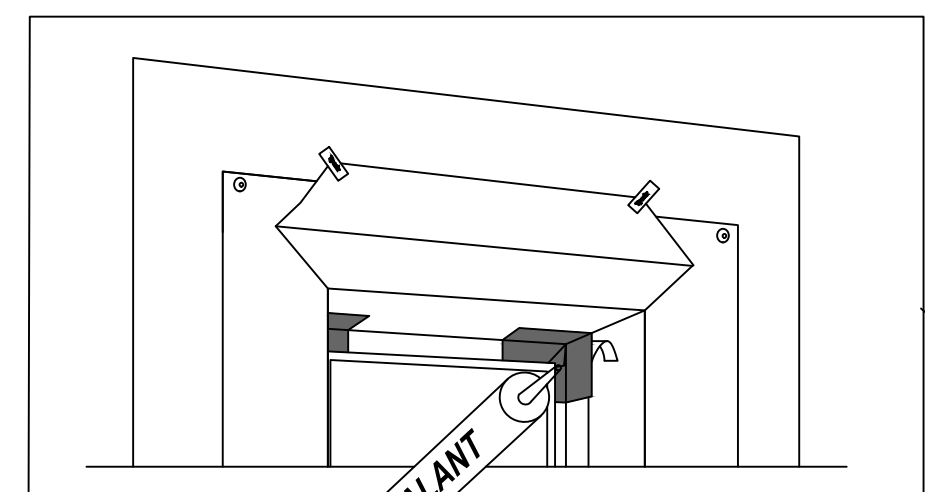

STEP 14

- A. INSTALL DUPONT™ FLEXWRAP™ NF RECESSED WINDOW CORNERS INTO THE UPPER CORNER OF THE WINDOW ROUGH OPENING WITH EXPOSED BUTYL ADHERED ONTO THE WINDOW FLANGES IN A SIMILAR MANNER USED FOR LOWER CORNER PIECES (SEE STEP 5).
- B. REMOVE REMAINING RELEASE PAPER AND ADHERE EXPOSED BUTYL ONTO HEAD AND JAMB WALLS OF RECESS.
- C. PLACE A BEAD OF DUPONT™ RESIDENTIAL SEALANT OR RECOMMENDED SEALANT INSIDE THE CORNER FLAP BEHIND THE LOOSE TRIANGULAR FLAP OF THE CORNER PIECE.
- D. REPEAT STEPS A THROUGH D FOR OPPOSITE CORNER.

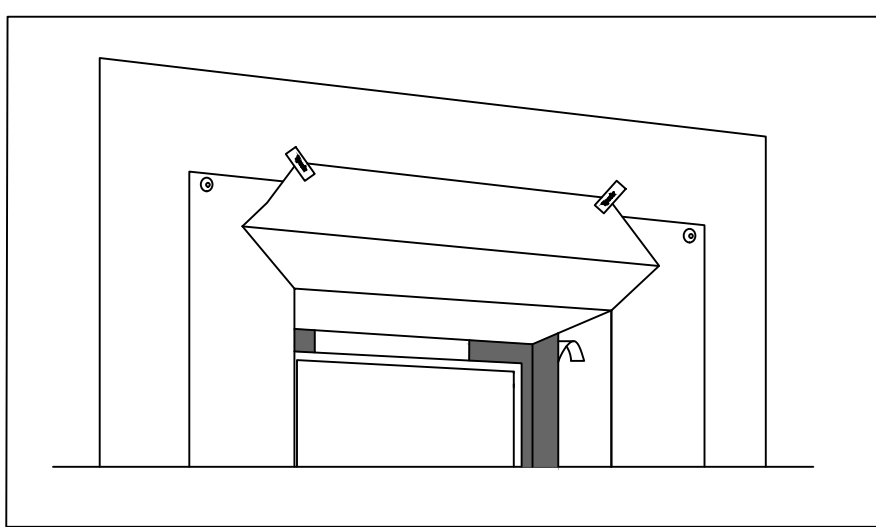

STEP 13

- A. CUT A PIECE OF DUPONT™ FLASHING TAPE 2" LONGER THAN THE LENGTH OF THE OUTER JAMB.
- B. FOLD LENGTHWISE TO CREATE A SHARP CREASE IN RELEASE PAPER THAT IS ALIGNED WITH THE INTERSECTION OF THE FACE OF THE STUD FRAMING AND JAMB WALL OF RECESS.
- C. STARTING AT THE BOTTOM, CUT A 2" VERTICAL SLIT IN THE DUPONT™ FLASHING TAPE ALONG THE CREASE. THIS WILL BE USED TO CREATE THE DUPONT™ FLASHING TAPE CORNER IN STEPS F AND H.
- D. REMOVE THE FIRST PIECE OF RELEASE PAPER TO EXPOSE THE BUTYL THAT WILL BE INSTALLED ONTO THE WINDOW FLANGE BY TEARING ALONG THE CREASE. LEAVE THE RELEASE PAPER ON THE 2" FLAP CREATED IN STEP C. DO NOT CUT RELEASE PAPER WITH SHARP OBJECT AS THIS COULD RESULT IN DAMAGE TO BUTYL AND COMPROMISE PROTECTION PROVIDED BY THE DUPONT™ FLASHING TAPE.
- E. STARTING AT THE TOP CORNER OF RECESS, ADHERE EXPOSED BUTYL ADHESIVE ONTO WINDOW FLANGE AND FACE OF STUD FRAMING.
- F. REMOVE THE RELEASE PAPER FROM THE CORNER FLAP IN THE DUPONT™ FLASHING TAPE CREATED IN STEP C, AND ADHERE THE FLAP TO THE SILL.
- G. ONCE BUTYL IS ADHERED TO THE WINDOW FLANGE, FACE OF STUD FRAMING, AND SILL, REMOVE THE REMAINING RELEASE PAPER - LEAVE THE RELEASE PAPER ON THE OTHER 2" FLAP CREATED IN STEP C. THE FLASHING CAN NOW BE ADHERED TIGHTLY INTO THE INSIDE CORNER CREATED BY THE STUD FRAMING AND JAMB WALL OF THE RECESS.
- H. REMOVE THE RELEASE PAPER FROM THE SECOND CORNER FLAP AND ADHERE OVER THE FIRST FLAP.
- I. APPLY DUPONT™ RESIDENTIAL SEALANT, OR RECOMMENDED SEALANT, TO THE INTERFACES AS SHOWN.
- J. REPEAT STEPS A THROUGH I FOR OPPOSITE JAMB.

WINDOW TO BE INSTALLED

STEP 12

- A. INSTALL WINDOW ACCORDING TO MANUFACTURER'S INSTALLATION INSTRUCTIONS.

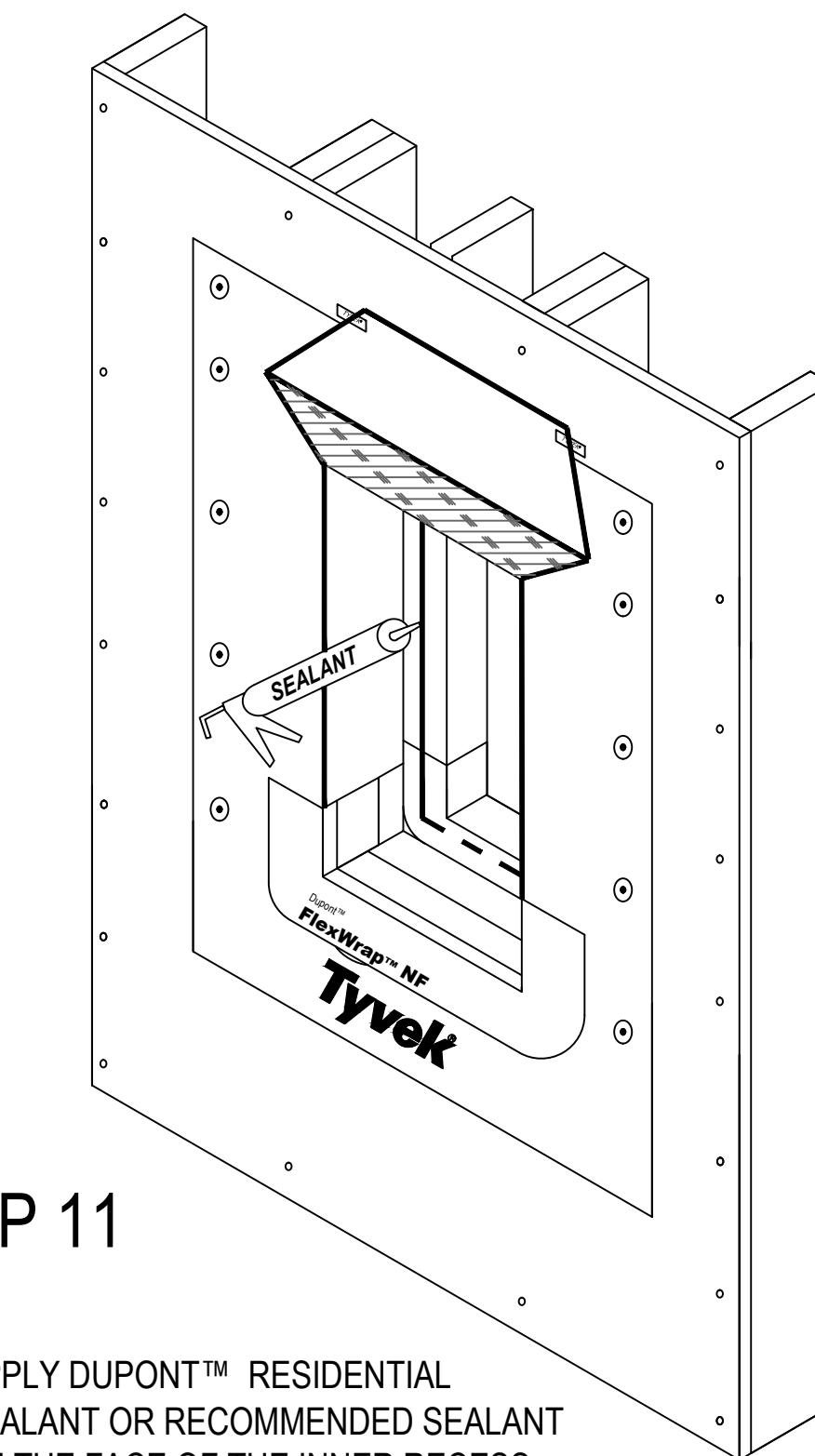

STEP 11

- A. APPLY DUPONT™ RESIDENTIAL SEALANT OR RECOMMENDED SEALANT ON THE FACE OF THE INNER RECESS FRAMING AT JAMBS AND HEAD AS SHOWN ABOVE. IF SEALANT IS APPLIED TO THE SILL, ENSURE THAT THERE ARE AT LEAST TWO (2) 2" GAPS IN THE SEALANT BEAD FOR EVERY 4" OF WINDOW TO ALLOW FOR DRAINAGE.

NOTES:

- FOR ADDITIONAL INFORMATION REGARDING PRODUCT INSTALLATION AND/OR FABRICATION INSTRUCTIONS FOR RECESSED WINDOW CORNERS, REFER TO THE APPLICABLE DUPONT™ SELF-ADHERED FLASHING SYSTEMS PRODUCTS INSTALLATION GUIDELINE.
- INSTALLATION IS APPLICABLE FOR BUILDINGS LESS THAN 5 STORIES AND LOW-RISE MULTI-FAMILY RESIDENTIAL BUILDINGS LESS THAN 6 STORIES WHEN PERFORMANCE REQUIREMENTS DO NOT EXCEED ASTM E1677 (65 MPH EQUIVALENT STRUCTURAL LOAD AND 15 MPH EQUIVALENT WIND-DRIVEN RAIN WATER INFILTRATION), AND WINDOW/DOOR DESIGN RATINGS THAT DO NOT EXCEED DP45.

INSTALLATION FOR RECESSED WINDOW CONDITIONS WHERE DEPTH OF RECESS IS GREATER THAN 1/2 THE WIDTH OF RECESS (METHOD 2)

Integral Flanged Window Recessed Greater Than 4" Before WRB Installation Sequence - Method 2

DRAWING:

R-OP-2180-2-MA, Page 2 of 3

REVISION DATE
11/1/2016
SCALE: Not to Scale



Tyvek.

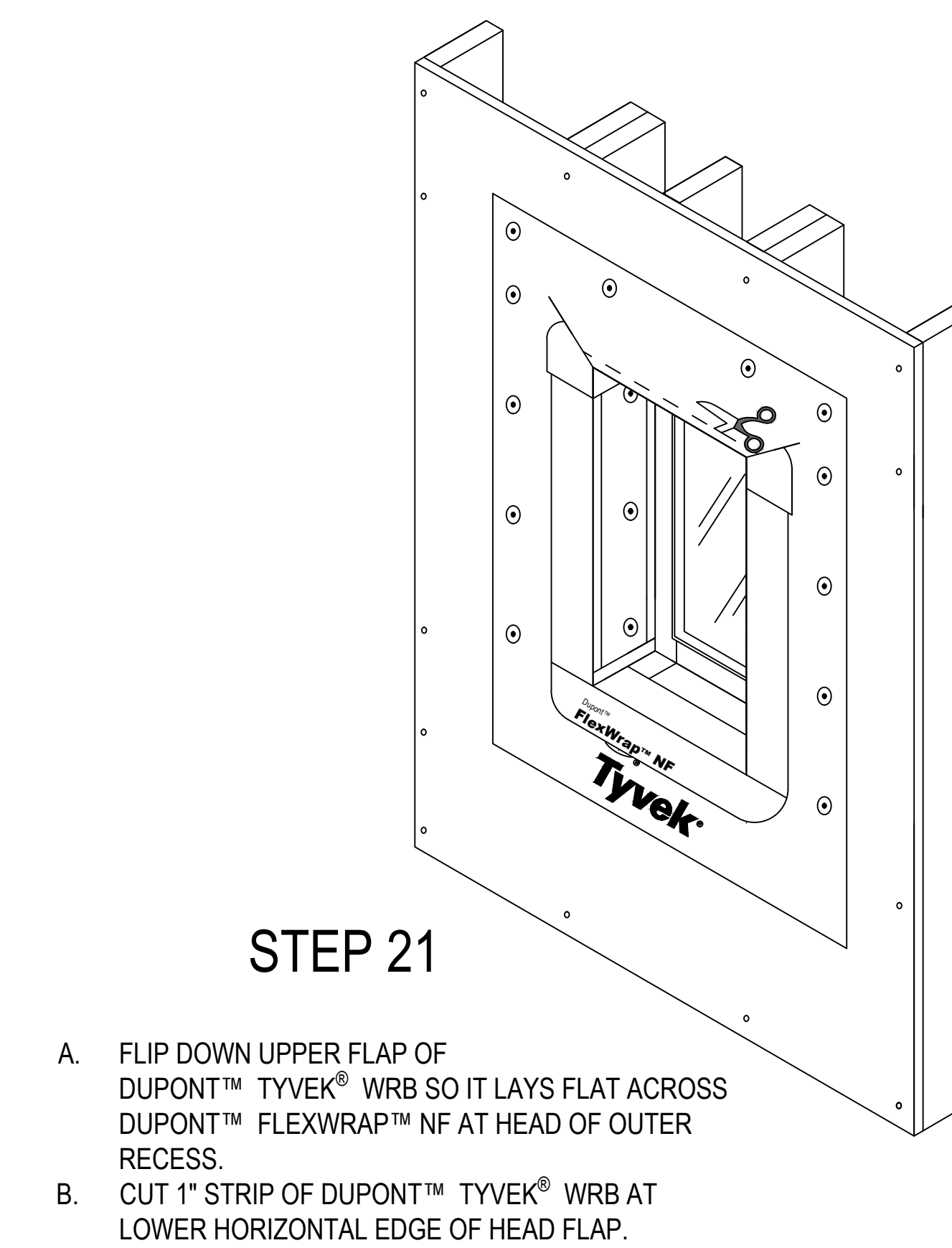
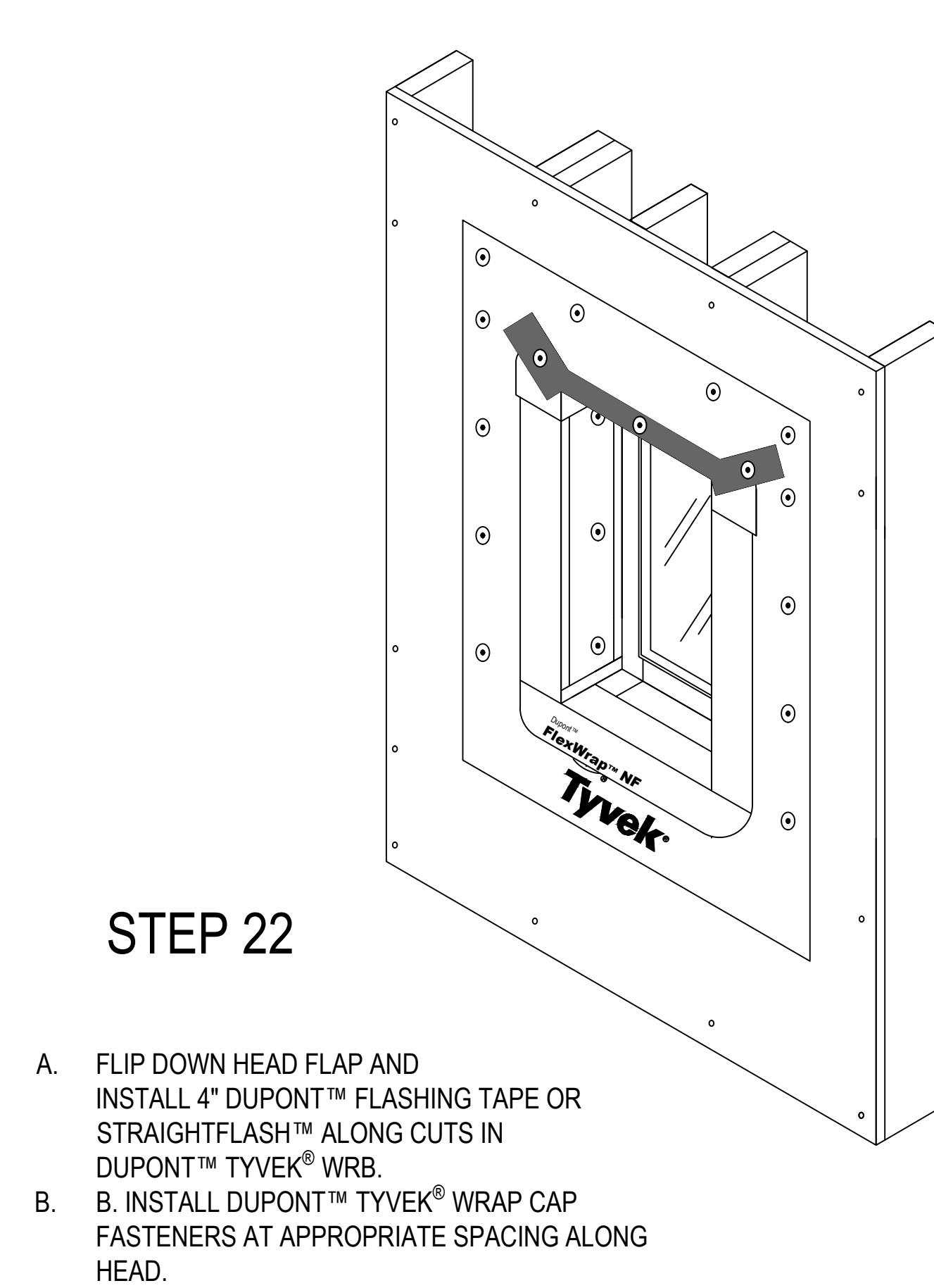
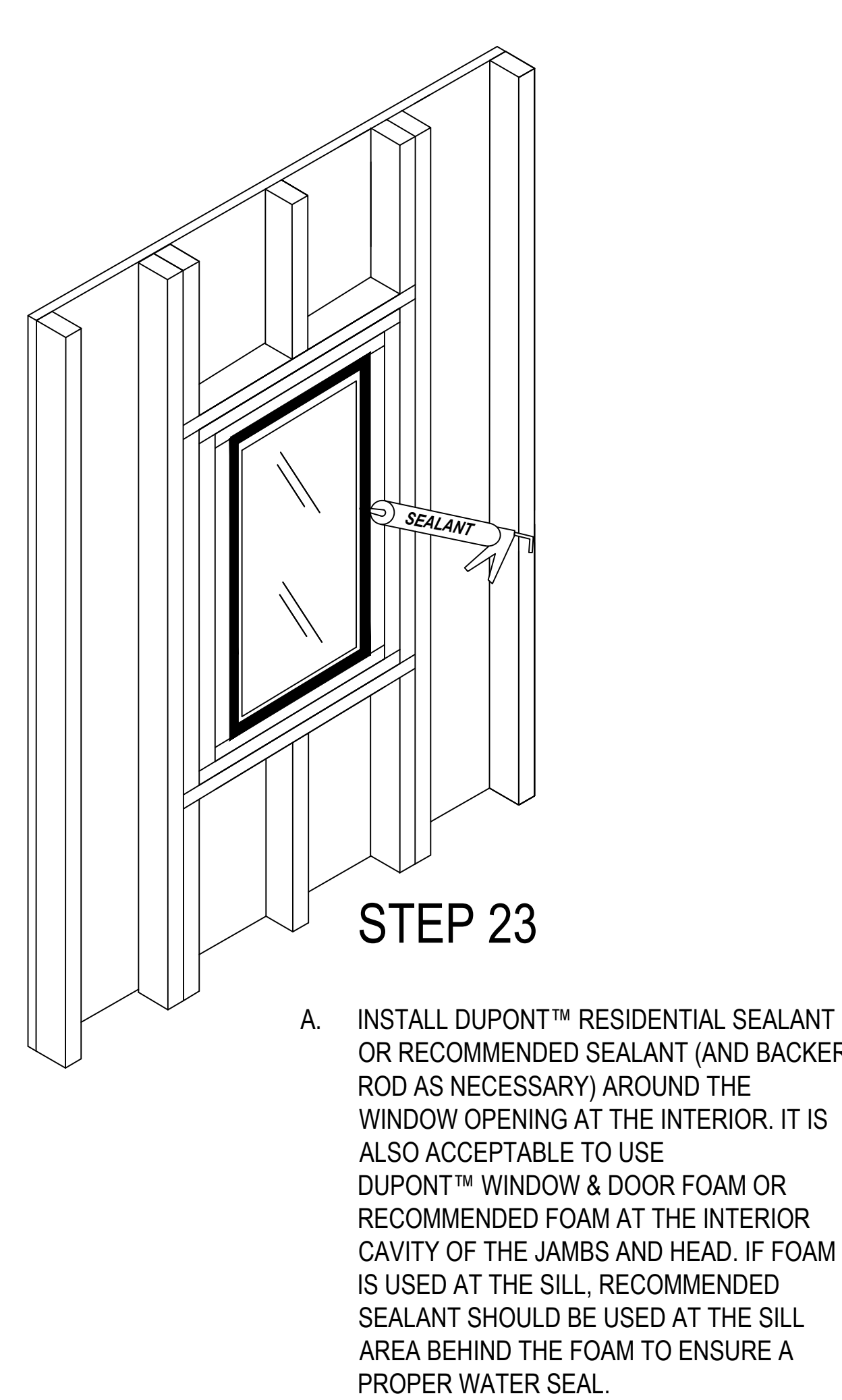
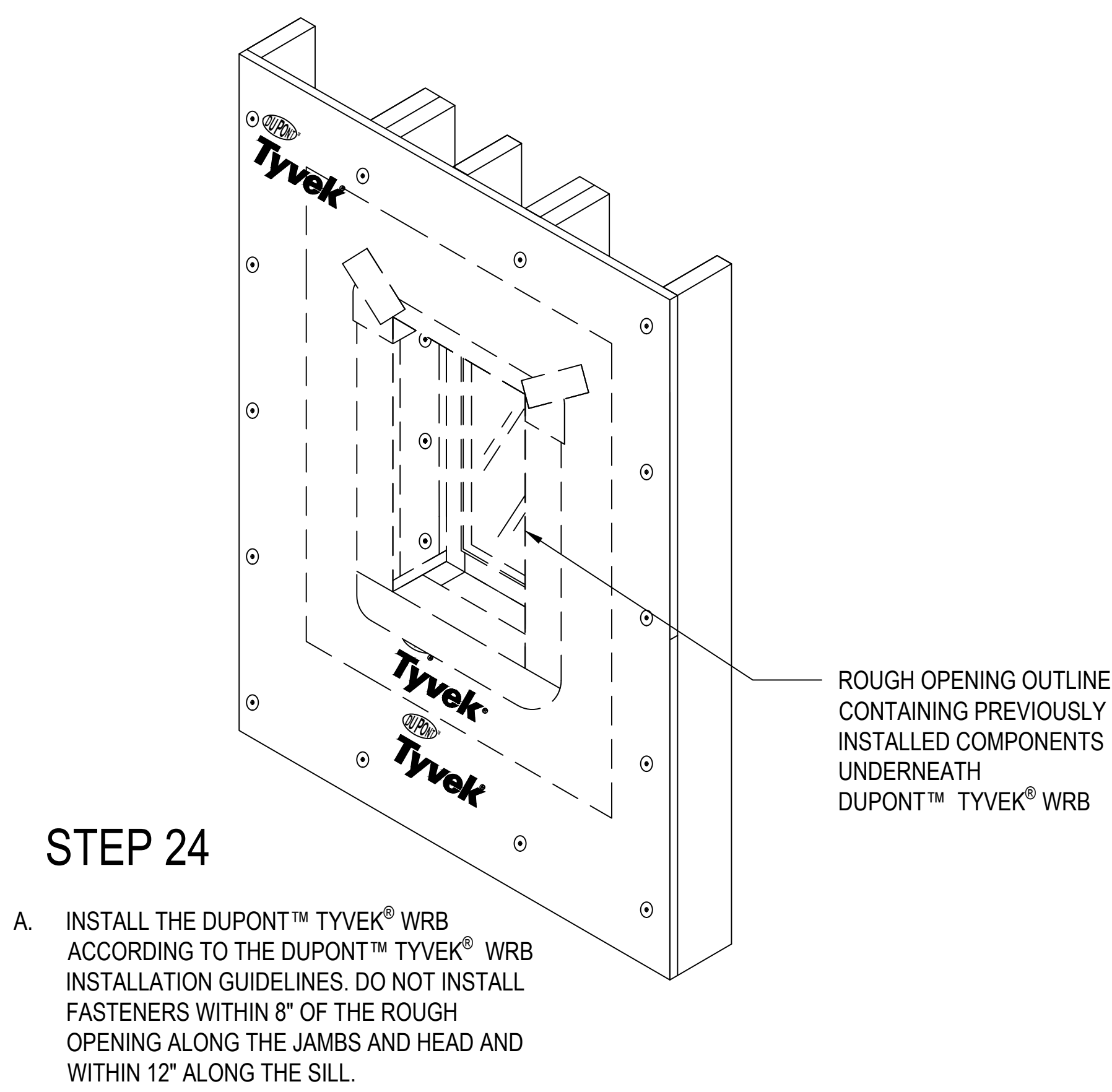
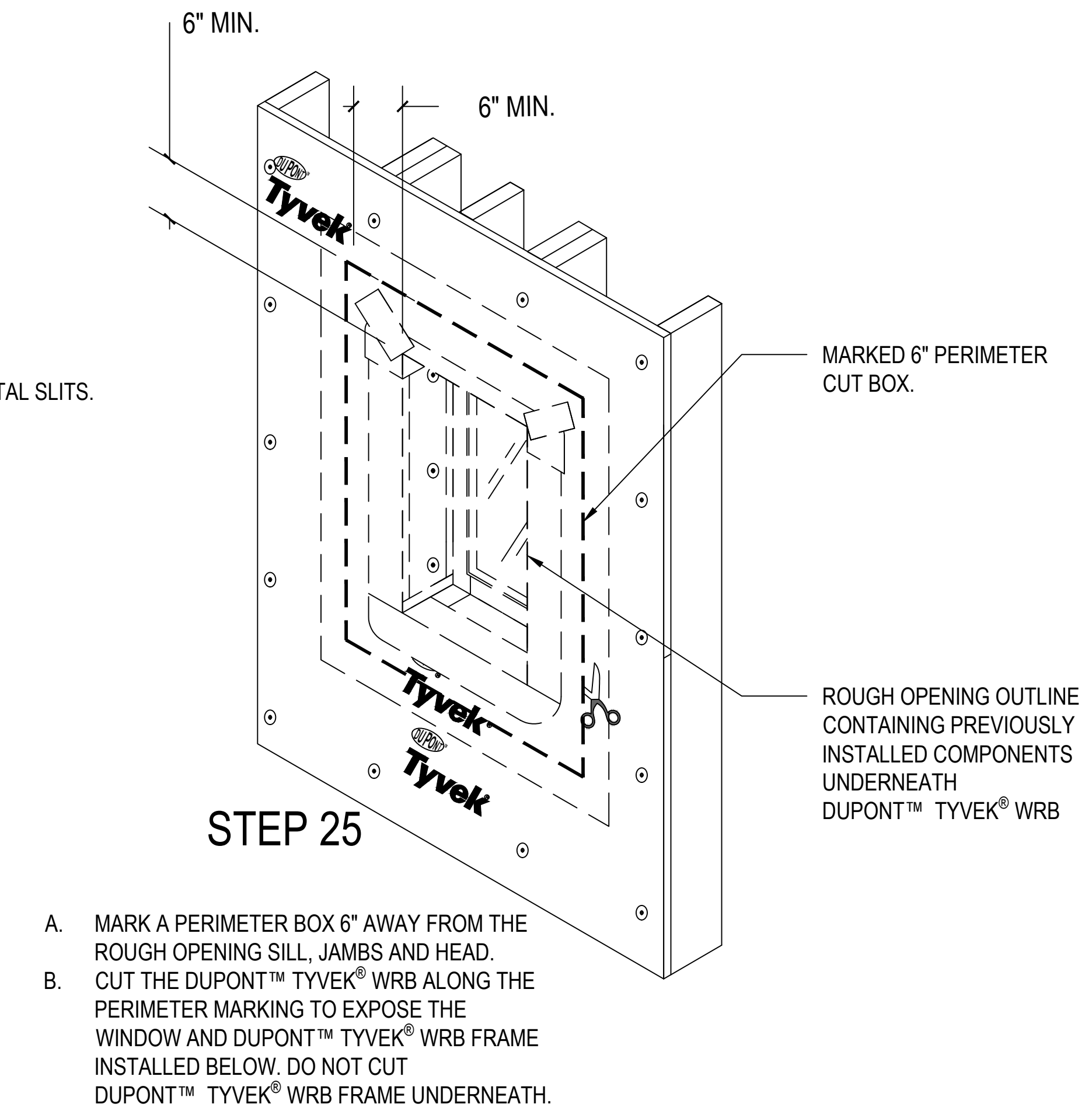
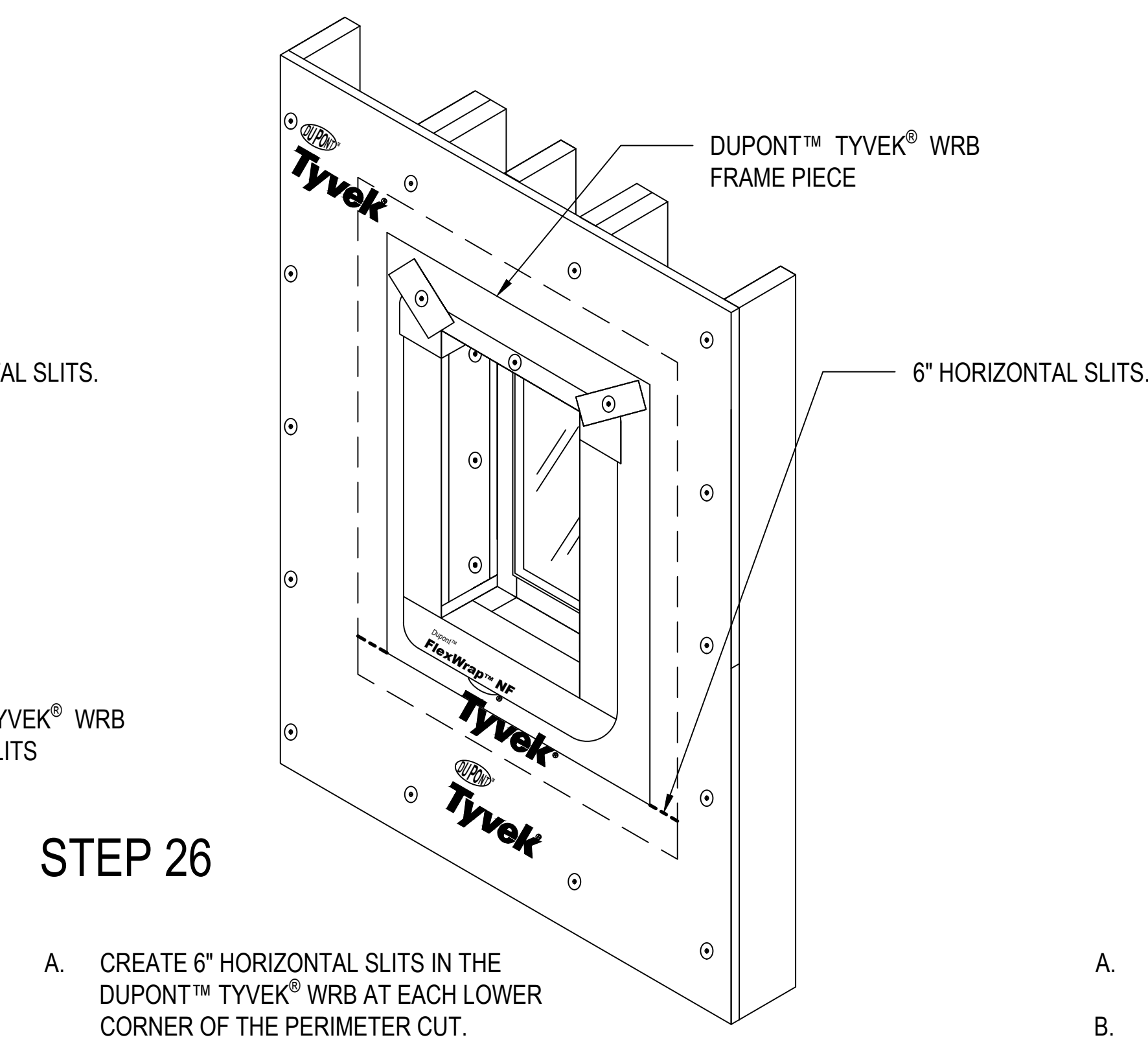
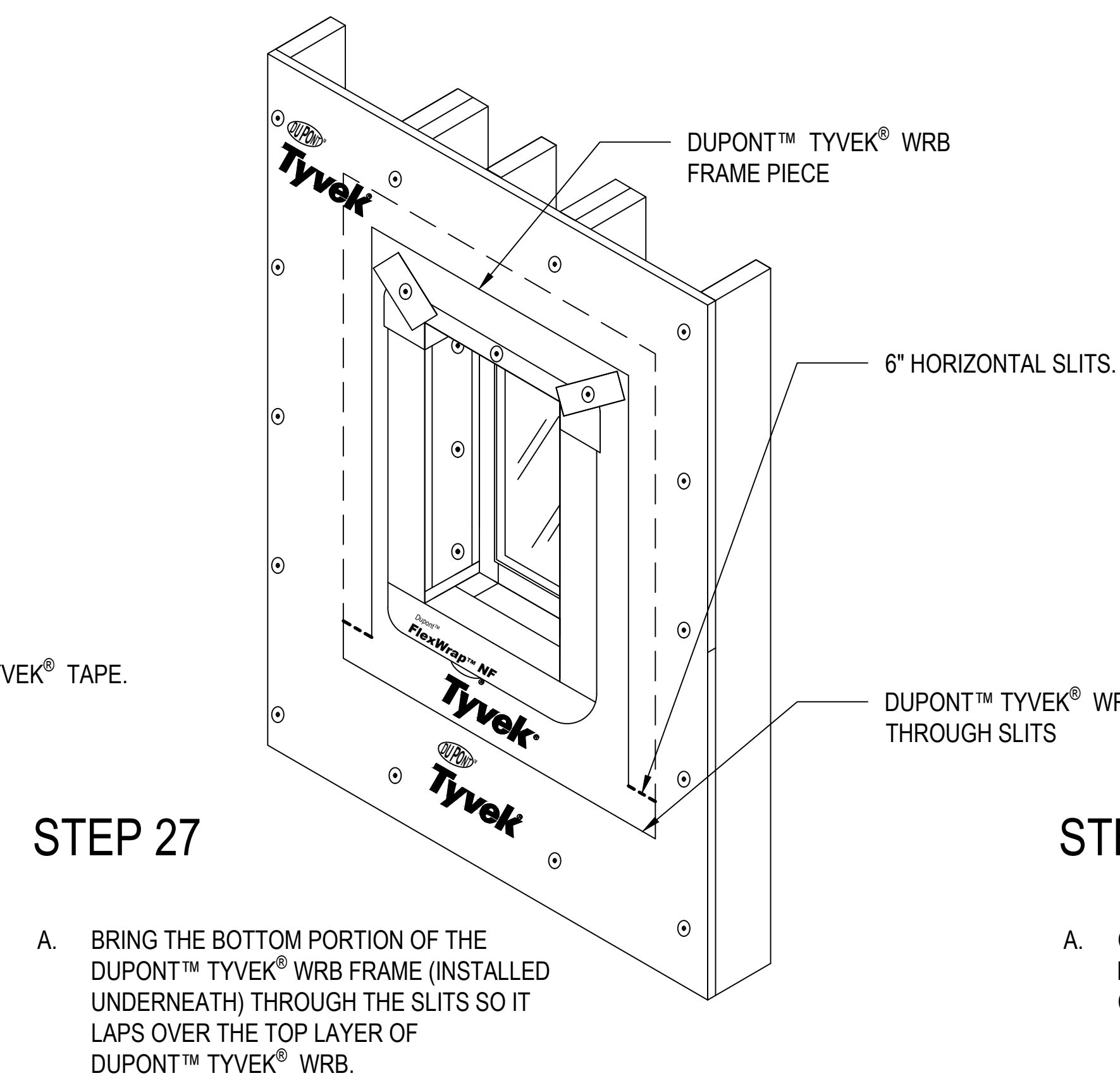
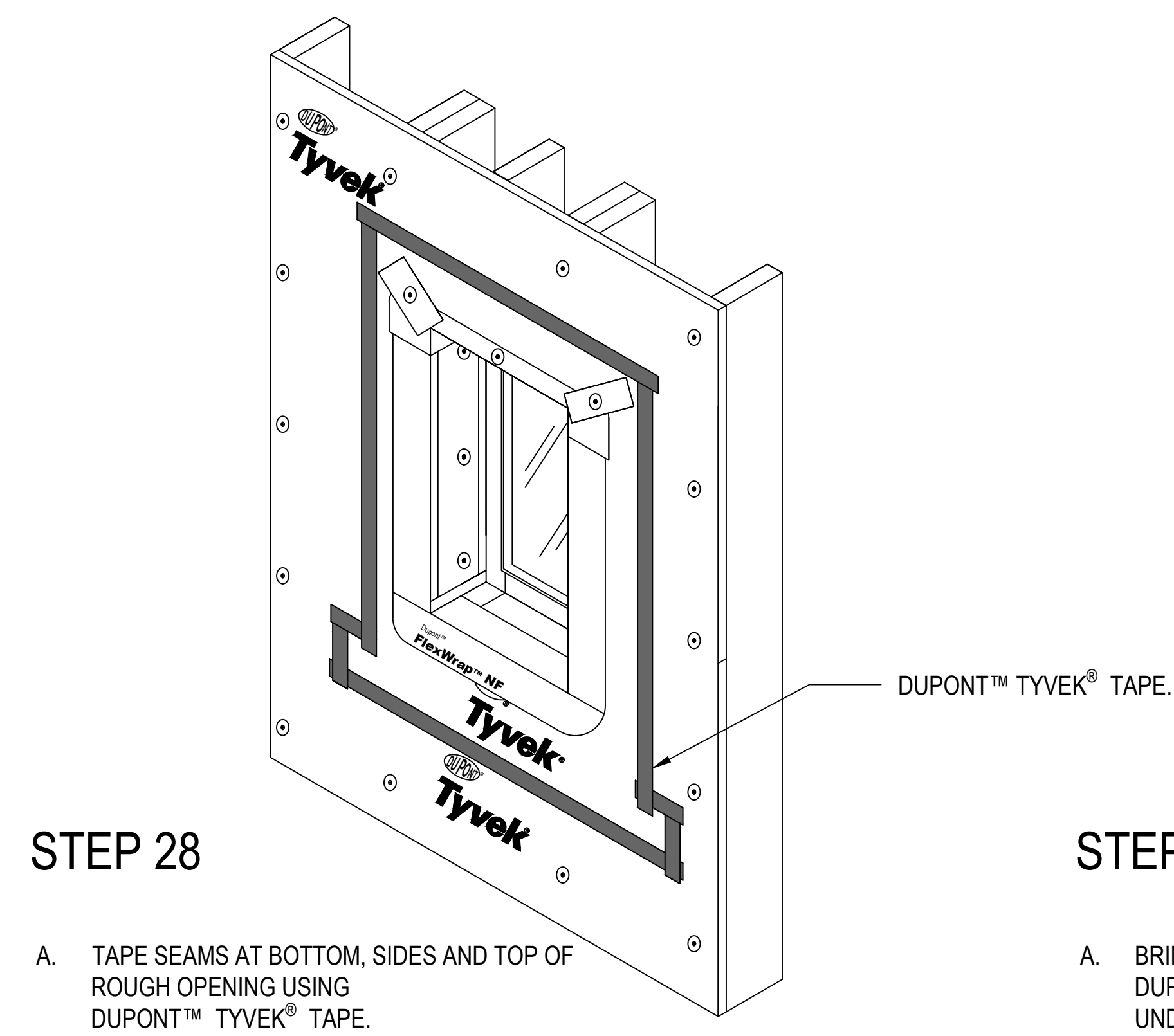

- NOTES:**
- FOR ADDITIONAL INFORMATION REGARDING PRODUCT INSTALLATION AND/OR FABRICATION INSTRUCTIONS FOR RECESSED WINDOW CORNERS, REFER TO THE APPLICABLE DUPONT™ SELF-ADHERED FLASHING SYSTEMS PRODUCTS INSTALLATION GUIDELINE.
 - INSTALLATION IS APPLICABLE FOR BUILDINGS LESS THAN 5 STORIES AND LOW-RISE MULTI-FAMILY RESIDENTIAL BUILDINGS LESS THAN 6 STORIES WHEN PERFORMANCE REQUIREMENTS DO NOT EXCEED ASTM E1677 (65 MPH EQUIVALENT STRUCTURAL LOAD AND 15 MPH EQUIVALENT WIND-DRIVEN RAIN WATER INFILTRATION), AND WINDOW/DOOR DESIGN RATINGS THAT DO NOT EXCEED DP45.

INSTALLATION FOR RECESSED WINDOW CONDITIONS WHERE DEPTH OF RECESS IS LESS THAN 1/2 THE WIDTH OF RECESS (METHOD 1)

Integral Flanged Window Recessed Greater Than 4" Before WRB Installation Sequence - Method 2

DRAWING:	REVISION DATE
R-OP-2180-2-MA, Page 3 of 3	11/11/2016
	SCALE: Not to Scale

